

MANUAL

Electronic circuit breaker BASIC SMART



TABLE OF CONTENTS

1 ... ORDERING DATA.....	3
2. .. GENERAL DATA	4
2.1 Safety instructions	4
2.2 Qualified personnel	4
2.3 Intended use	4
2.4 Disclaimer.....	4
2.5 Installation	4
3. .. Product description	6
4. .. Operating and display elements	7
5. .. Tripping characteristic.....	8
5.1 Tripping characteristic up to 6A.....	8
5.2 Tripping characteristic up to 12A	9
6. .. Selective immediate switch-off in the event of undervoltage	9
7.... Charging of capacitive loads	10
7.1 Capacities for devices with max. 6A rated current.....	10
7.2 Capacities for devices with max. 12A rated current.....	10
8. .. Operating states, signalling, reactions	11
8.1 Switch-on delays of individual channels.....	11
8.2 Button „ON/OFF and Reset“	12
8.3 Signalling and control contacts S1/S2/S3.....	12
8.4 Functionality of 2-wire communication via S1/S2.....	13
8.5 Communication sequence via S1/S2	13
8.6 Details of signal input S1 (ON/OFF/RESET).....	14
8.7 Details on signal output S2 (status of the outputs).....	17
8.8 Details on signal output S3 (Σ for triggered outputs and device fault)	18
9. .. Dimensions	18

1. ORDERING DATA

The following table shows the ordering data for the charging and control unit and the battery modules.

Table 1: Ordering numbers

Variant	Input voltage	Output current	Channels
PC-0824-480-0	24 Vdc	0,5 – 6A	8
PC-0824-480-1	24 Vdc	0,5 – 6A	8
PM-0824-120-0	24 Vdc	0,5 – 6A	2
PM-0824-120-1	24 Vdc	0,5 – 6A	2
PM-0824-240-0	24 Vdc	2 – 12A	4
PM-0824-240-1	24 Vdc	0,5 – 6A	4
PM-0824-240-2	24 Vdc	2 – 12A	2
PM-0824-480-0	24 Vdc	2 – 12A	4

2. GENERAL DATA

2.1 Safety instructions

Please read these warnings and safety instructions carefully before operating the appliance. The device may only be installed by specialised and qualified personnel. In the event of malfunctions or damage, switch off the supply voltage immediately and send the appliance to BLOCK Transformatoren-Elektronik GmbH for inspection. The device does not contain any service parts. If an internal fuse blows, there is most probably an internal defect in the appliance. The data provided are for product description purposes only and are not to be regarded as warranted characteristics in the legal sense.

2.2 Qualified personnel

The product associated with this documentation may only be handled by qualified personnel in compliance with the documentation associated with the respective task, in particular the safety instructions and warnings contained therein. Qualified personnel can ensure, based on their training and experience, that the use of the described product fulfils all safety requirements as well as the applicable provisions, regulations, standards and laws.

2.3 Intended use

This device is designed for installation in a housing and is suitable for use in general electronic devices, such as industrial control systems, office equipment, communication devices or measuring devices. Do not use this device in the control systems of aeroplanes, trains or nuclear facilities where a malfunction could result in serious injury or danger to life.

2.4 Disclaimer

The contents of this publication have been checked with the utmost care to ensure that they correspond to the hardware and software described. Nevertheless, there may be discrepancies between the product and the documentation. Deviations may also occur due to the continuous further development of the product.

For this reason, we cannot guarantee complete conformity. Should this documentation contain errors, we reserve the right to make any necessary corrections without prior notice.

2.5 Installation

Installation must be carried out in accordance with local conditions, relevant regulations, national accident prevention regulations and the recognised rules of technology. This electrical equipment is a component intended for installation in electrical systems or machines and fulfils the requirements of the Low Voltage Directive (2014/35/EU). The required minimum distance to neighbouring parts must be maintained in order not to impede cooling!



ATTENTION

Switch off the input voltage before carrying out installation, maintenance or modification work and secure it against unintentional switching on again.



ATTENTION

Do not make any changes or attempts to repair the appliance. Do not open the device!



ATTENTION

Prevent the ingress of foreign objects such as paper clips and metal parts.



ATTENTION

Do not operate the appliance in a damp environment or in an environment where condensation or condensation is to be expected.



ATTENTION

Do not touch the housing during operation or shortly after switching off.
Hot surfaces can cause injuries.

3. Product description

The BASIC SMART circuit breakers guarantee maximum system availability. If a circuit is overloaded, only the faulty current path is reliably disconnected thanks to active current limiting to 1.7 times the rated current without affecting the other circuits. A voltage dip on unaffected circuits is reliably prevented.

The tripping current of each output can be set individually using a current selector switch accessible from the front. The outputs are switched on with a time delay and load-dependent in order to avoid peak inrush currents. If the rated current is exceeded, the output is automatically switched off after a defined tripping time and can be switched on again after a short waiting time (thermal release) using a push-button or signal contact. The push-button is also used to switch off the respective output manually. Signal contacts can be used to read out information relevant to operation and to switch individual outputs on or off. A 24 V cumulative error signal for triggered outputs is also available. The status of the respective output is displayed via a multi-coloured LED.

- Number of available output channels: 2 / 4 / 8
- Adjustable rated current per channel
- Reliable switching on of high capacitive loads
- Sequential and load-dependent switching of the channels
- Status monitoring and remote switching of the outputs via 2 lines
- Deactivation of faulty circuits with critical supply voltage
- Extended remote transmission of input voltage, set nominal currents and current output currents
- Sum signalling contact for simple remote diagnostics
- Push-in direct or pluggable connection technology

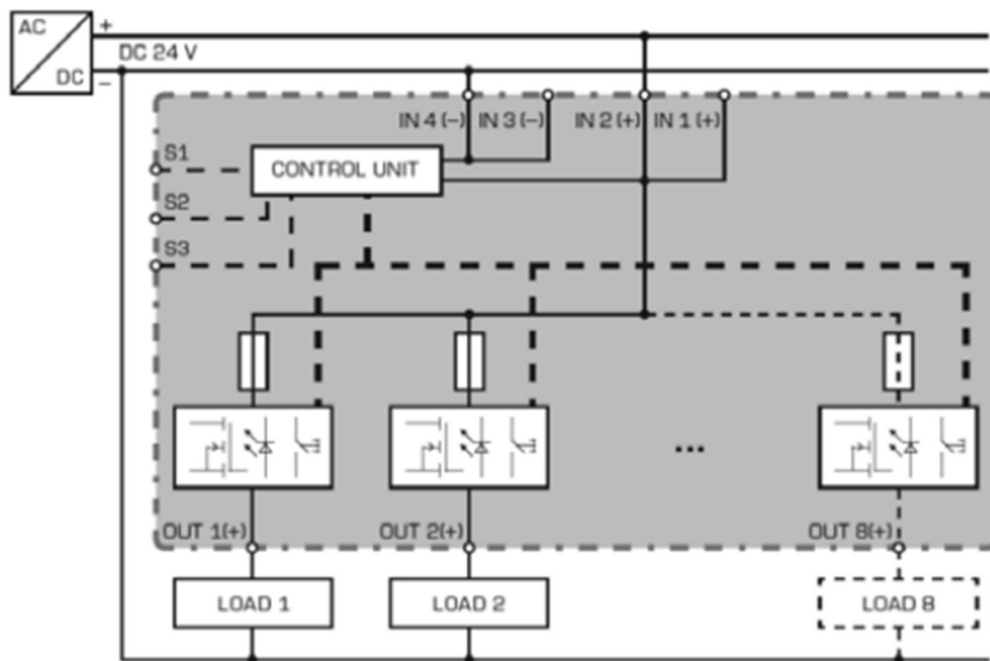

Functional diagram

4. Operating and display elements



Front view with operating and display elements

5. Tripping characteristic

5.1 Tripping characteristic up to 6A

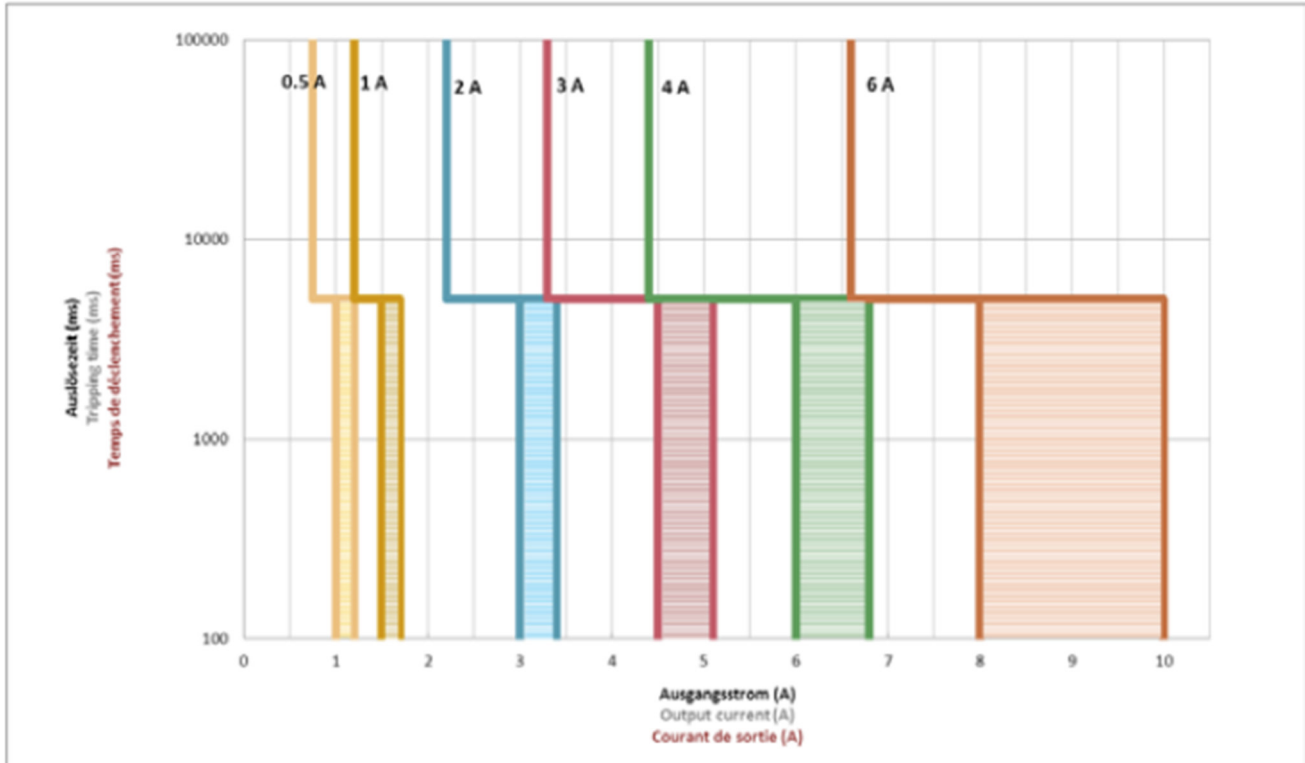

Set rated current	Switch-off occurs after max. 5 s with overcurrents >	Switch-off occurs within 50 ms ... 5s if overcurrent between:	
0,5 A	0,75 A	1,00 A	1,20 A
1 A	1,20 A	1,50 A	1,70 A
2 A	2,20 A	3,00 A	3,40 A
3 A	3,30 A	4,50 A	5,10 A
4 A	4,40 A	6,00 A	6,80 A
6 A	6,60 A	8,00 A	10,0 A

The electronic circuit breaker actively limits the overcurrent of each output channel to typically 1.7 times the set nominal current, see right-hand column in the table above. The switch-off time varies between 50 ms and 5 s depending on the level of the overcurrent. In the event of an overcurrent, only the faulty circuit is selectively switched off. A voltage dip on unaffected circuits is reliably prevented.

5.2 Tripping characteristic up to 12A

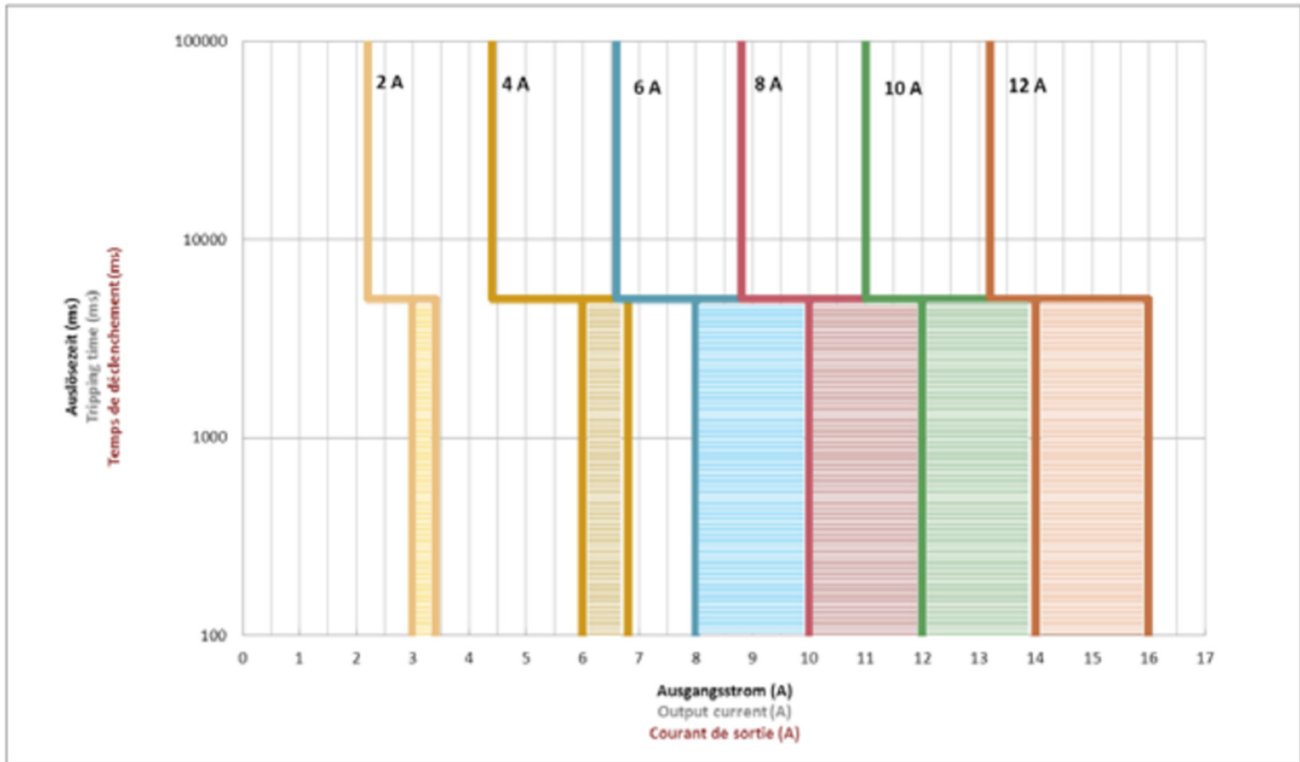

Set rated current	Current limitation	Switch-off occurs after max. 5s in the event of overcurrent >	Switch-off occurs within 50 ms ... 5 s if overcurrent between:	
2 A	1,7 x Rated current	2,2 A	3 A	3,4 A
4 A		4,4 A	6 A	6,8 A
6 A		6,6 A	8 A	10 A
8 A	1,5 x Rated current	8,8 A	10 A	12 A
10 A	1,4 x Rated current	11 A	12 A	14 A
12 A	1,3 x Rated current	13,2 A	14 A	16 A

The electronic circuit breaker actively limits the overcurrent of each output channel to the set limiting current, see right-hand column in the table above. The switch-off time varies between 50 ms and 5 s depending on the level of the overcurrent. In the event of an overcurrent, only the faulty circuit is selectively switched off. A voltage dip in unaffected circuits is reliably prevented.

6. Selective immediate switch-off in the event of undervoltage

If the power supply output voltage falls below 20 V, all outputs that carry more than 100% of the individually set tripping current at this moment are selectively switched off immediately (max. 16 ms).

7. Charging of capacitive loads

The electronic circuit breaker enables particularly high capacitive loads to be switched on. The following experimentally determined capacitances serve as reference values.

7.1 Capacities for devices with max. 6A rated current

Cable cross-section: 0,75mm²

Cable length (outgoing and return line)	Switch-on capacitance [mF] at 22 V input voltage	Switch-on capacitance [mF] at 24 V input voltage	Switch-on capacitance [mF] at 26 V input voltage	Switch-on capacitance [mF] at 28 V input voltage
0	80	74,3	51,5	42
2,5	82,5	72	57,8	48,8
5	100	78	63	51
10	126,8	96,8	75,3	61
20	189,3	145,2	109,8	82
40	>620	>620	243	167,3

Leitungsquerschnitt: 1,5mm²

Cable length (outgoing and return line)	Switch-on capacitance [mF] at 22 V input voltage	Switch-on capacitance [mF] at 24 V input voltage	Switch-on capacitance [mF] at 26 V input voltage	Switch-on capacitance [mF] at 28 V input voltage
0	80	64,8	51,5	43,3
2,5	86,8	69,3	54,3	43,8
5	91,5	78,3	61,5	45
10	99,3	86,8	66,8	50
20	131,5	102,5	89,3	62,5
40	201,5	152,5	102,5	86,8

Leitungsquerschnitt: 2,5mm²

Cable length (outgoing and return line)	Switch-on capacitance [mF] at 22 V input voltage	Switch-on capacitance [mF] at 24 V input voltage	Switch-on capacitance [mF] at 26 V input voltage	Switch-on capacitance [mF] at 28 V input voltage
0	80	64,8	51,5	42,5
2,5	83,3	67,8	52,3	43,3
5	84,3	69,3	54,3	44,3
10	89,3	71,1	56,8	46,8
20	109,3	86,8	67,8	54,3
40	136,8	107,8	82	65,3

All capacities were determined experimentally under nominal load. The tasks are guide values, possible line capacities depend on the installation situation. The supplying power supply unit must be able to supply the required current without the output voltage dropping to less than 18V.

7.2 Capacities for devices with max. 12A rated current

Minimum capacitance: **137mF** @Vdc

The capacitance was determined experimentally at 12A rated current, with a cable length of 2.5m and a cable cross-section of 2.5mm².

8. Operating states, signalling, reactions

Z	Operating status	Output	LED	Signal output S3 (sum signal)	Button is pressed	Signal input S1 (on/off/reset)
0	Module initialisation (1)	Off	Off	0 V	---	---
1	Outputs switched on Function OK	On	Green	24 V	Switch off Output Z3	Via bit pattern → Switch off output Z3
2	Output current > Rated current (2)	On	Flashing green	24 V	Switch off Output Z3	Via bit pattern → Switch off output Z3
3	Output is switched off manually or via signal input S1 (3)	Off	Red	0 V	Switch on Output Z1	Via bit pattern → Switch on output Z1
4	Output is switched off due to an overcurrent Thermal expansion is active (4)	Off	Flashing Red	0 V	---	---
5	Output is switched off due to an overcurrent Thermal overload has ended (5)	Off	Flashing orange	0 V	Switch on Output Z3	Long 24V pulse (>0,5s) → switch on output
6	Device error (defective fuse detected)	Off	Fast flashing orange	0 V	---	---

- 1) Once module initialisation is complete, the outputs are switched on depending on the load.
- 2) The output is automatically switched off according to the tripping characteristic.
- 3) The status is saved when the device is switched off.
- 4) After a waiting time (thermal relaxation), transition to operating state Z5. When the appliance is switched off, the remaining waiting time is saved and waited for when it is switched on again. This reliably prevents overloading of the switching elements even if the appliance is switched on again immediately.
- 5) The affected output can be switched on again by pressing the button twice or via a pulse (>0,5s) at signal input S1, transition to operating state Z1.

8.1 Switch-on delays of individual channels

The outputs are switched on sequentially after a minimum input voltage (switch-on threshold) is reached. To reduce inrush current peaks, all channels are switched on depending on the load.

The channels are switched on starting with the smallest channel number to be switched on, typically starting with channel 1. The next channel is switched on as soon as the output current of the previous channel is below the set nominal value or the previous output has been switched off, but not before 50 ms.

8.2 Button „ON/OFF and Reset“

A push-button is assigned to each output channel. The current status is displayed via an integrated LED. The button has two functions depending on the operating status:

- Normal operation
If the channel is switched off (button lights up permanently red), it can be switched on by briefly pressing it (button lights up green). Pressing it again switches the output off again.
- Faulty operation
If the output channel is switched off due to an overcurrent (button flashes red), it can be switched on again (reset).

NOTE:

To switch the output back on, the thermal expansion must first be completed (button flashes yellow instead of red). After pressing the button, the output is initially switched off (button lights up red continuously). Pressing the button again switches the output on again. (button lights up green continuously).

The outputs are switched on in the delivery state.

8.3 Signalling and control contacts S1/S2/S3

The electronic circuit breaker is equipped with three signalling and control contacts.



Signal contacts S1 (digital input) and S2 (digital output) can be used to read out operationally relevant information from the circuit breaker and to switch any output channels on or off in a targeted manner.

A sum reset (switching back on) of all triggered outputs (outputs not switched off manually) is also possible via signal input S1, provided a 24V high pulse is fed in for at least 0.5 seconds.

The signal output S3 serves as an active 24V collective fault signal and indicates that at least one output has been switched off due to overcurrent. An internal device fault is also signalled by S3.

8.4 Functionality of 2-wire communication via S1/S2

The circuit breaker can be remotely controlled via a higher-level control system (e.g. PLC) using a serial bit pattern at signal input S1. At the same time, the operating and fault statuses, the input voltage applied to the module, the set nominal current and the current flowing in each circuit are made available via the signal output S2.

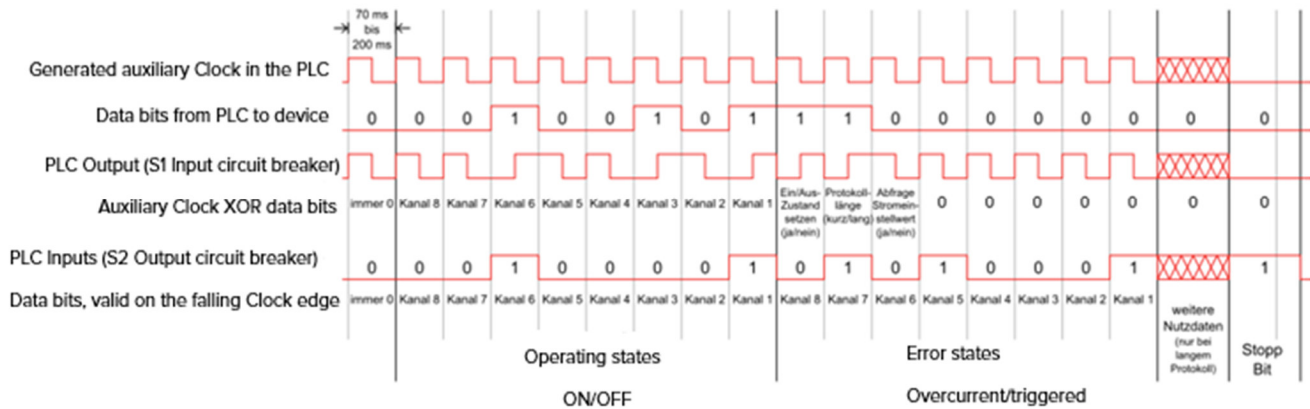

Diagnostic options via S1/S2:

Short protocol: (17 bit data - minimum transmission time 1.2 seconds)

Operating states = on or off per channel

Error states = overcurrent or tripped per channel

Extended protocol: (89 bit data - minimum transmission time 6.3 seconds)

Current input voltage

Set nominal currents per channel

Current current per channel (only applies to BASIC SMART equipment)

8.5 Communication sequence via S1/S2

- A digital output of the control unit sends the Manchester coding to the circuit breaker via 'S1'. This encodes which output channel is to be switched on or off.
- The circuit breaker synchronises itself internally to this and simultaneously sends back the status (on/off and error status) of all channels via 'S2'. In addition to the module input voltage, the currently flowing current and the set current value of each circuit can optionally be queried, see 'Extended protocol'.
- The data sent back by the circuit breaker is only high/low and not Manchester-coded. The data should be accepted shortly after the edge change (from high to low) of the generated auxiliary clock in order to avoid false signalling due to program runtimes or delays of the I/Os in a PLC.
- Once all 17 or 89 bits for the extended protocol have been successfully received, the circuit breaker sends an 18th or 90th bit as a stop bit. This takes 1.5 clock cycles. During this time, the PLC must not send another bit.

Coding of the status bits sent by the circuit breaker

On/off status per channel	Error status per channel	Description
0	0	Output channel is switched off manually or via coded pulse pattern on S1
0	1	Output channel is switched off due to an overcurrent
1	0	Output channel is switched on manually or via coded pulse pattern on S1
1	1	Overcurrent (output current > rated current) (duration of the overcurrent is ≥ 1 second)

NOTES:

The on/off status changes sent by a higher-level control system are only sent back updated by the circuit breaker with the next telegram. If, for example, the status of output channel 3 is changed from '0' to '1' in a telegram, the old status '0' is transmitted in the same telegram. The status of the output channel is only sent updated by the circuit breaker the next time it is queried by the control system.

Programme examples (function) for various PLC series can be downloaded free of charge from the product page of this device on the Internet at [BASIC SMART \(block.eu\)](https://www.block.eu).

8.6 Details of signal input S1 (ON/OFF/RESET)

This 24V signal input is not electrically isolated in relation to the 0V input of the module. This input can be used to switch on all outputs that have been switched off due to overload as well as to switch individual channels on or off.

Reset (reactivation of triggered channels)

By applying a 24V voltage for longer than 0.5 seconds, all outputs triggered by an overload are switched on again sequentially and load-dependently.

Remote on/off

Any outputs can be switched on or off simultaneously using coded pulse patterns. Temporary circuits such as certain lights or auxiliary circuits can be switched off as required.

Function	Action	Reaction	Impuls
Reset	Long pulse $\geq 500\text{ms}$	all outputs switched off due to overload are switched on again. Triggered channels are only reactivated after 0V detection. This prevents automatically triggered channels from being switched on again in the event of a continuous signal	 <p>Switching on all triggered channels</p>
ON/OFF	Coded pulse pattern	Switching non-triggered outputs on and off. Triggered outputs cannot be switched on or off. They must first be acknowledged by a reset pulse.	See description of the pulse pattern below

Description Pulse pattern

The pulse pattern consists of 17 or optionally 89 bits, which must be sent as a Manchester code (in accordance with IEEE 802.3). The first bit to be transmitted has the value '0' and serves as the start bit. This is followed by 16 or optionally 88 bits of user data.

The first 8 bits represent the desired on/off status of the individual channels in descending order. A value of '1' switches the corresponding channel on, a value of '0' switches it off. For the following 8 bits, only the first three most significant bits are relevant.

- Bit 7 = '1': the on/off status transmitted in the first 8 bits is accepted
- Bit 7 = '0': the on/off status transmitted in the first 8 bits is ignored
- Bit 6 = '1': the extended 89-bit protocol is used, the circuit breaker transmits additional user data
- Bit 6 = '0': the short 17-bit protocol is used
- Bit 5 = '1': the rated currents set on the current selector switch and the current input voltage are transmitted
- Bit 5 = '0': the current input voltage and, for all circuit breakers in the '**BASIC SMART**' configuration, the current output currents are transmitted.

The following 6 or optionally 78 bits must be set to '0' and serve as a clock signal for the signal output 'S2'.

Once all 17 or 89 bits have been successfully received, the circuit breaker sends an 18th or 90th bit as a stop bit. This takes 1.5 clock cycles. During this time, the PLC must not send another bit. After the pulse pattern has been sent, S1 and S2 are set to low level again.

New pulse patterns on S1 are only permitted after a waiting time of at least 200ms

Standard protocol (17 bit)

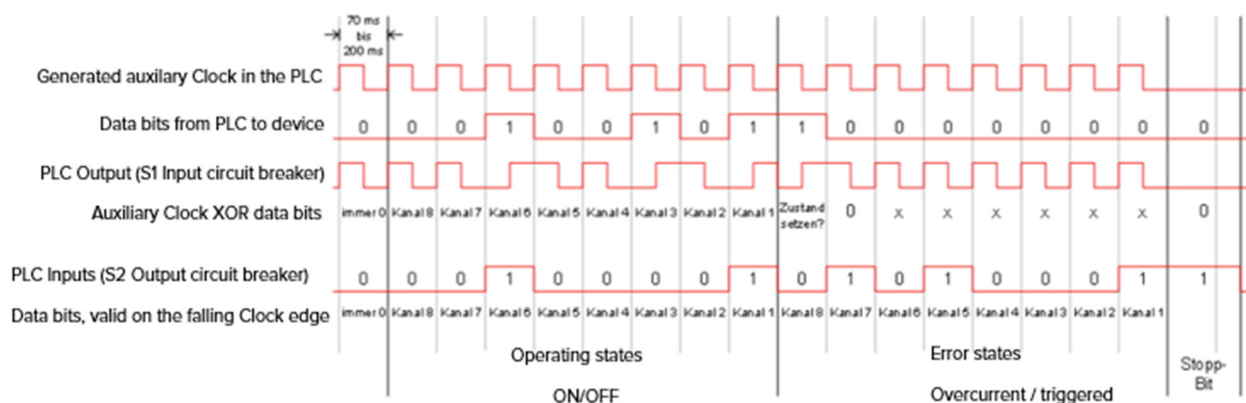

Extended protocol (89 bit)

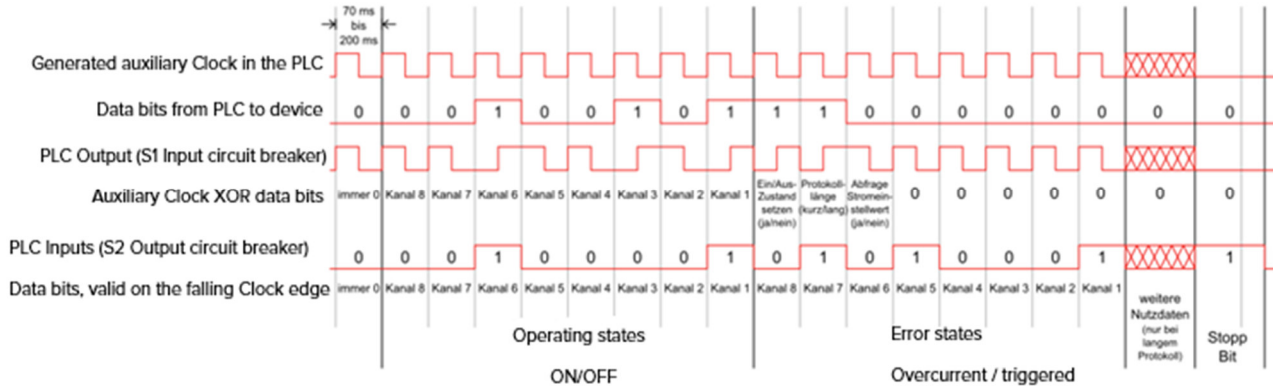

It begins with the 3rd byte of the protocol (further user data) and contains a total of 9 bytes. These are coded with the most significant bit first ('MSB first') and have the following meaning:

(Depending on the value of bit 5 in the 2nd byte, either the set nominal currents or the current output currents (only equipment 'BASIC SMART') are transmitted in addition to the current input voltage.

- Input voltage: ((transmitted value) /16 + 16) V
- Current channel 1: (transmitted value) /16 A
- Current channel 2: (transmitted value) /16 A
- Current channel 3: (transmitted value) /16 A
- Current channel 4: (transmitted value) /16 A
- Current channel 5: (transmitted value) /16 A
- Current channel 6: (transmitted value) /16 A
- Current channel 7: (transmitted value) /16 A
- Current channel 8: (transmitted value) /16 A

8.7 Details on signal output S2 (status of the outputs)

This 24V signal output is not electrically isolated in relation to the 0V input of the module. This output can be used to query the status of all integrated output channels. The output is short-circuit-proof, the short-circuit current is approx. 25 mA.

Coded pulse sequence for status enquiry, generated by the PLC

If the PLC sends the coded pulse sequence via signal input S1, the circuit breaker synchronises to the auxiliary clock of the PLC and sends the current on/off status of the channels in data byte 1 via signal output S2. Tripped channels are coded in data byte 2.

Cyclical pulse after status change, generated by the circuit breaker

If the PLC does not perform a cyclical status request, the circuit breaker on S2 generates a cyclical pulse if the error status changes and the status is not requested regularly within the next 3 seconds. The internal fault status changes when at least one output is switched off or overcurrent occurs. This pulse is sent until the PLC has successfully queried the updated status via a new Manchester-coded telegram.



A digital input of the control system must therefore query the signal contact S2 in order to be informed of status changes in the circuit breaker. At the same time, the control system must be programmed to avoid starting a telegram via S1 while a pulse is being generated on S2 by the circuit breaker. It is recommended to evaluate the respective status on S2 before starting to send the telegram or to generate a telegram to query the status at least every 3 seconds.

8.8 Details on signal output S3 (Σ for triggered outputs and device fault)

This 24V signal output is not electrically isolated in relation to the 0V input of the module. The sum signal is realised by an 'Active High' signal output. If no output has triggered and no internal device fault has been detected, this signal output is 'Active High' (+24V). As soon as at least one output channel has triggered or a device defect has been detected, the signal output switches to 'Active Low' (0V). This signal output is short-circuit-proof and can be loaded up to max. 20 mA.

9. Dimensions

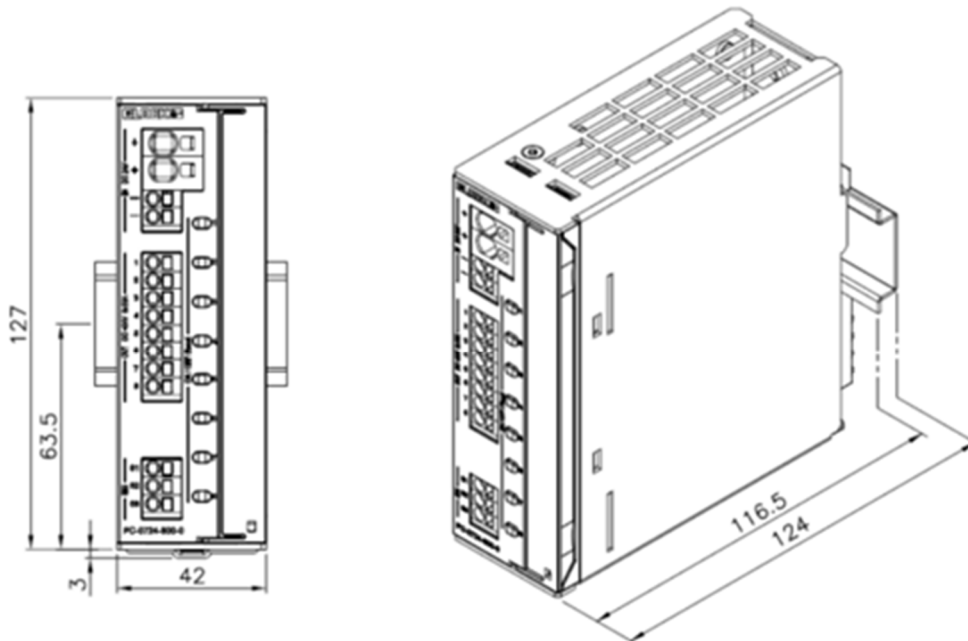

Dimensions 8-channel modules

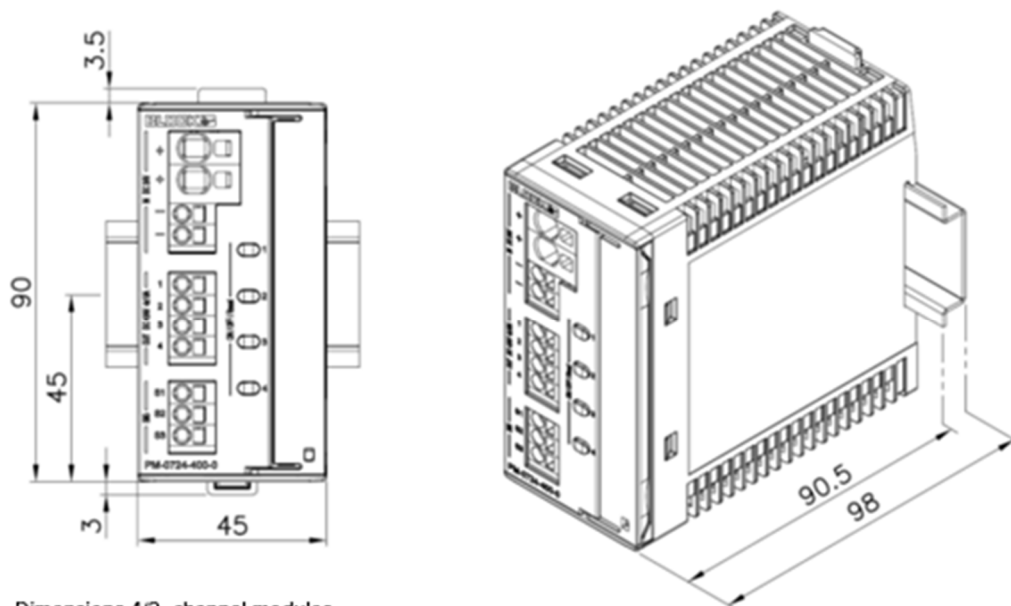

Dimensions 4/2- channel modules

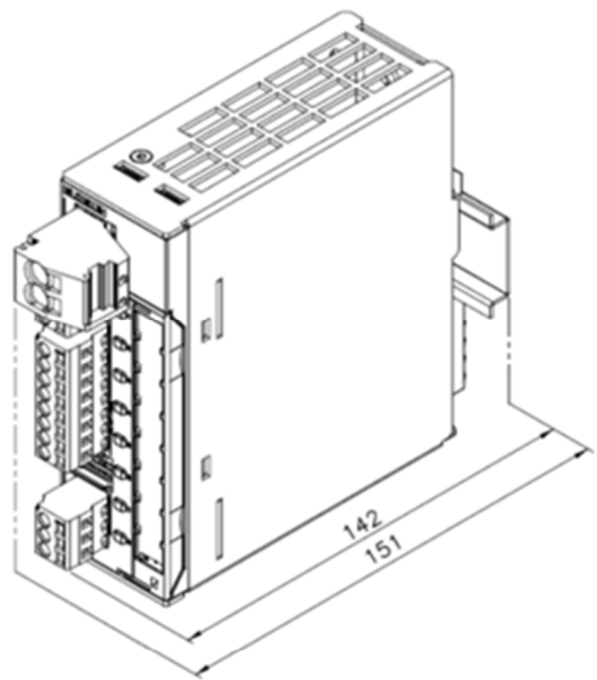
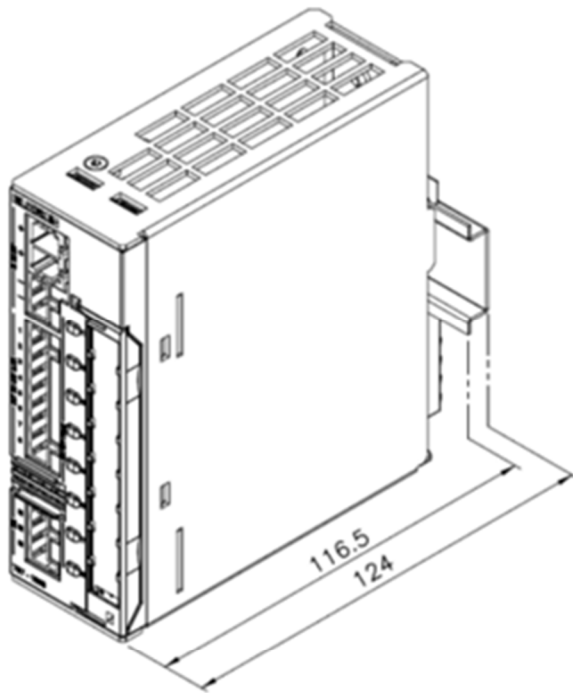

Dimensions 4-channel modules with pluggable Connection technology

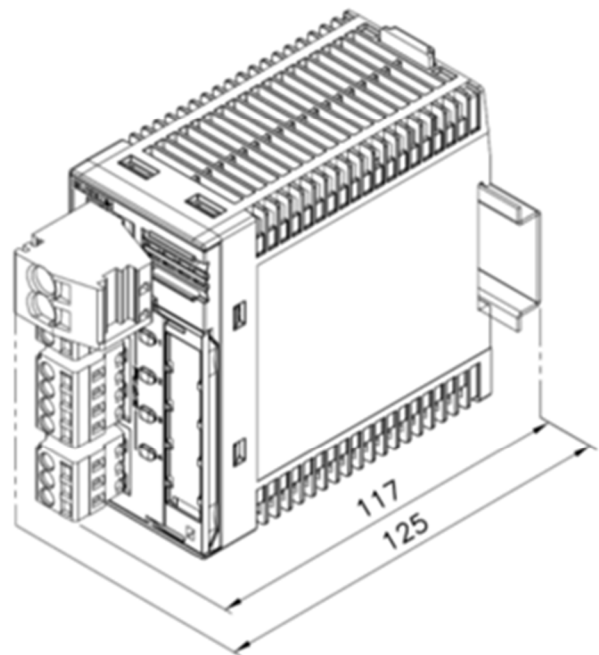
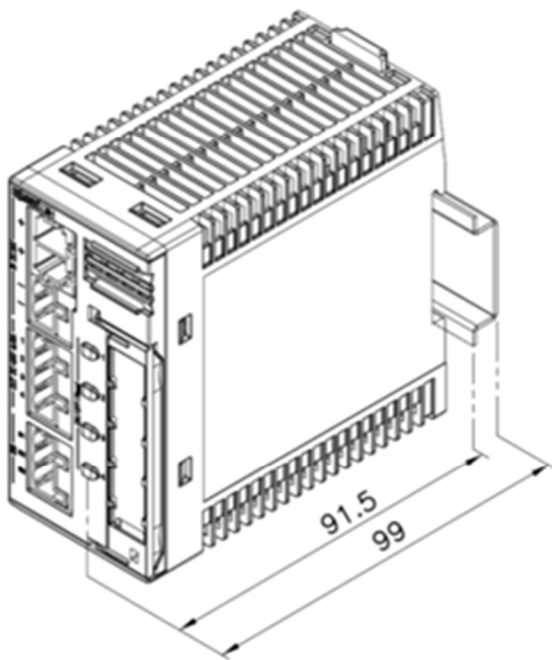

Dimensions 4/2-channel modules with pluggable Connection technology