

# MANUAL

Uninterrupted  
Power supply

Batterymodul  
**PST-0124**



# TABLE OF CONTENTS

<b>1 ... ORDERING DATA.....</b>	<b>3</b>
<b>2 .. GENERAL INFORMATION.....</b>	<b>4</b>
2.1 Safety.....	4
2.2 Qualified personnel .....	4
2.3 Intended use .....	4
2.4 Disclaimer.....	4
<b>3. .. PRODUCT.....</b>	<b>6</b>
3.1 Block diagram .....	7
3.2 Dimensioning.....	8
3.3 Assembly.....	10
<b>4. .. Commissioning .....</b>	<b>12</b>
4.1 Battery.....	12
4.2 Buffer times of the battery modules.....	13
<b>5. .. Maintenance.....</b>	<b>14</b>
5.1 Battery module life .....	14
5.2 Storage of the battery modules.....	14
<b>6. .. Disposal and Recycling.....</b>	<b>15</b>

## 1. ORDERING DATA

The following table shows the order data of the charging and control unit and the battery modules.

Table 1: Order Numbers

Loading and control unit			
Variant	Input voltage	Output current	
PC-1024-050-0	24 Vdc	5A	
PCC-1024-050-2U	24 Vdc	5A	
PCC-1024-050-20	24 Vdc	5 A	
PCC-1024-100-2U	24 Vdc	10A	
PCC-1024-100-20	24 Vdc	10 A	
PC-0524-400-0	24 Vdc	40 A	
PVUA 24/24-10	24 Vdc	10 A	
PVUA 24/24-20	24 Vdc	20 A	
Battery modul			
Variant	Input voltage	Output current	Capacity
PST-0124-032-00	24 Vdc	max. 20 A	3,2 Ah
PST-0124-070-00	24 Vdc	max. 40 A	7 Ah
PST-0124-120-00	24 Vdc	max. 40 A	12 Ah
PST-0124-120-10	24 Vdc	max. 40 A	12 Ah

### UPS-Control Software

Visualization and configuration software for the charging and control unit. Free download at [www.block.eu](http://www.block.eu). For the display and individual setting of the loading and control unit.

## 2. GENERAL INFORMATION

### 2.1 Safety

Please read these warnings and safety instructions carefully before using the device. The device may only be installed by competent and qualified personnel. In the event of malfunctions or damage, immediately switch off the supply voltage and send the device to BLOCK Transformatoren-Elektronik GmbH for inspection. The device does not include any service components. If an internal fuse is tripped, there is most likely an internal defect in the device. The data provided are for product description purposes only and are not to be regarded as warranted properties in the legal sense.

### 2.2 Qualified personnel

The product associated with this documentation may only be handled by qualified personnel in compliance with the documentation related to the respective task, in particular the safety and warning instructions contained therein. Qualified personnel can guarantee on the basis of their training and experience that the use of the described product meets all safety requirements as well as the applicable regulations, regulations, standards and laws.

### 2.3 Intended use

This device is designed to be installed in an enclosure and is suitable for use with general electronic devices, such as industrial controls, office equipment, communication equipment or measuring instruments. Do not use this device in control systems of aircraft, trains or nuclear facilities where malfunction could result in serious injury or danger to life.

### 2.4 Disclaimer

The content of this publication has been checked with the greatest care for compliance with the hardware and software described. Nevertheless, there may be discrepancies between the product and the documentation. Deviations can also occur due to the constant further development of the product. For this reason, we cannot guarantee complete compliance. If this documentation contains errors, we reserve the right to make necessary corrections without prior notice.



**ATTENTION**

Switch off the input voltage before installation, maintenance or modification work and protect it against unintentional reconnection.



**ATTENTION**

Do not make any modifications or repair attempts to the device. Do not open the device!



**ATTENTION**

Prevent the ingress of foreign objects, such as paper clips and metal parts.



**ATTENTION**

Do not operate the appliance in a humid environment or in an environment where condensation or condensation.



**ATTENTION**

Do not touch the housing during operation or shortly after shutting down. Hot surfaces can cause injuries.

### 3. PRODUCT

The battery module, in combination with a charging and control unit and a suitable external power supply, forms an uninterruptible power supply (UPS). This UPS protects the system and sensitive data from mains failures and voltage fluctuations. Depending on the application, either up to 20A or up to 40A are available without interruption with 24V networks. The UPS always ensures a secure supply of industrial PCs.



Figure 1: Battery Modules PST-0124-032-00 / PST-0124-070-00

### 3.1 Block diagram

The following block diagram shows a wiring example.

To ensure good communication between the battery modules and the charging and control unit, interface, control and signal cables < 3 meters must be selected.

In addition, care must be taken not to lay the control cable parallel to power lines, otherwise disturbances in communication are to be expected.

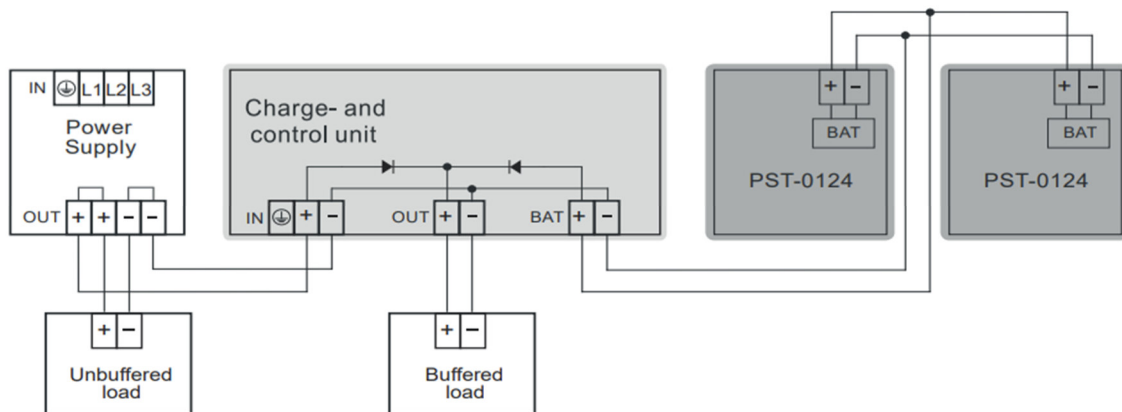

Figure 1: Wiring block diagram

To get the maximum buffer time, it is possible to connect up to 3 battery modules in parallel.

### 3.2 Dimensioning

The dimensions of the Batteries can be seen in Figure 3 - 6

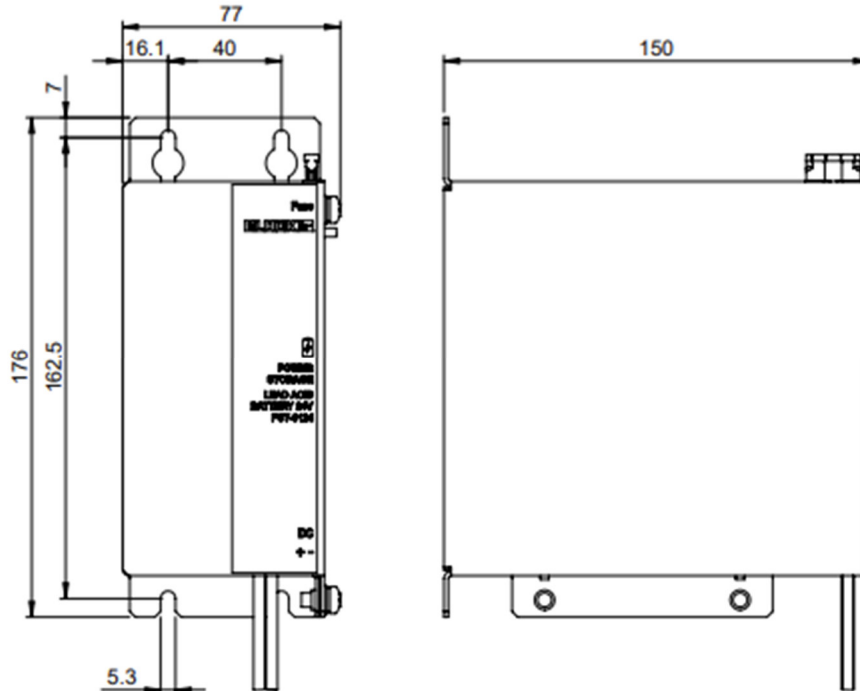

Figure 3: Dimension PST-0124-032-00

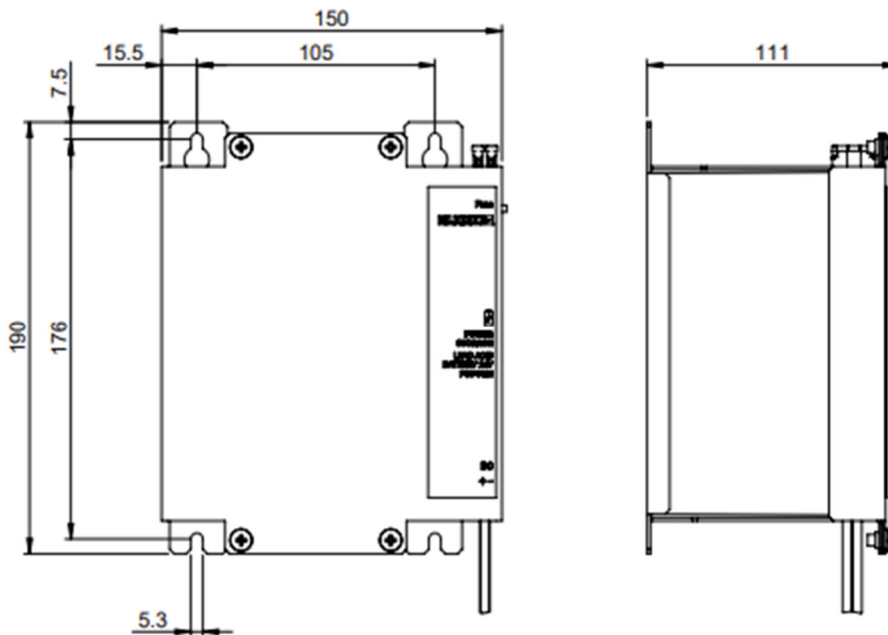

Figure 4: Dimension PST-0124-070-00



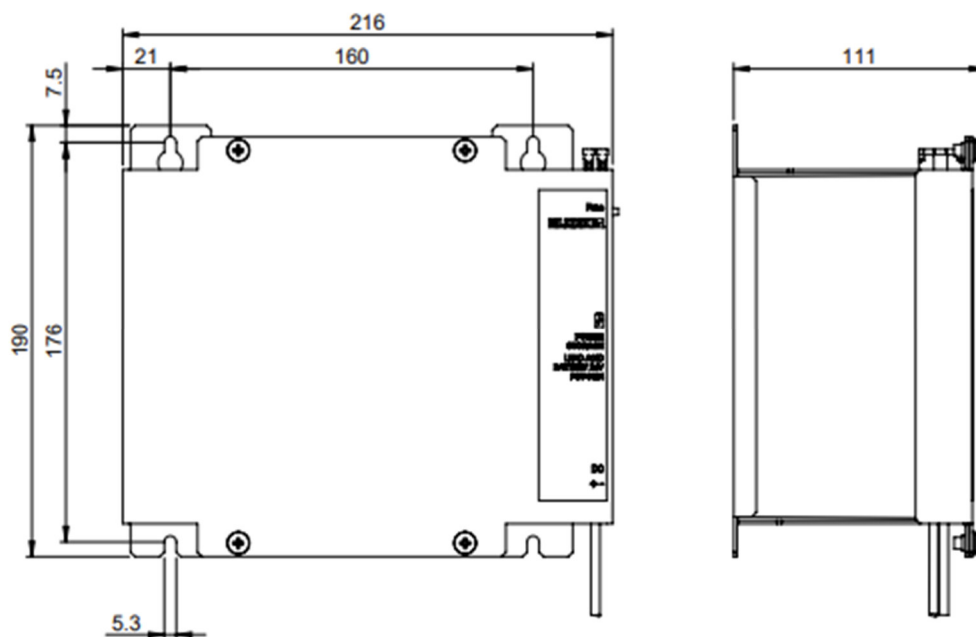

Figure 5: Dimension PST-0124-120-00

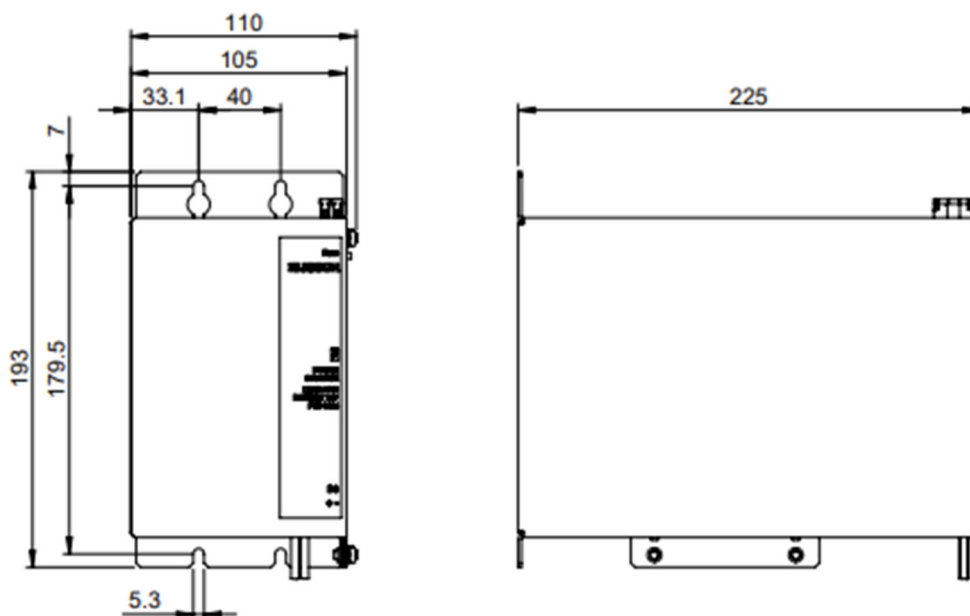

Figure 6: Dimension PST-0124-120-10

### 3.3 Assembly

The battery module is mounted via a direct screw connection. To do this, simply screw the two upper screws into the wall, then hook the battery module into the screws at the attachment points provided. After hooking in, the lower screws can be mounted so that the battery module rests on the lower screws. Then tighten all four screws.

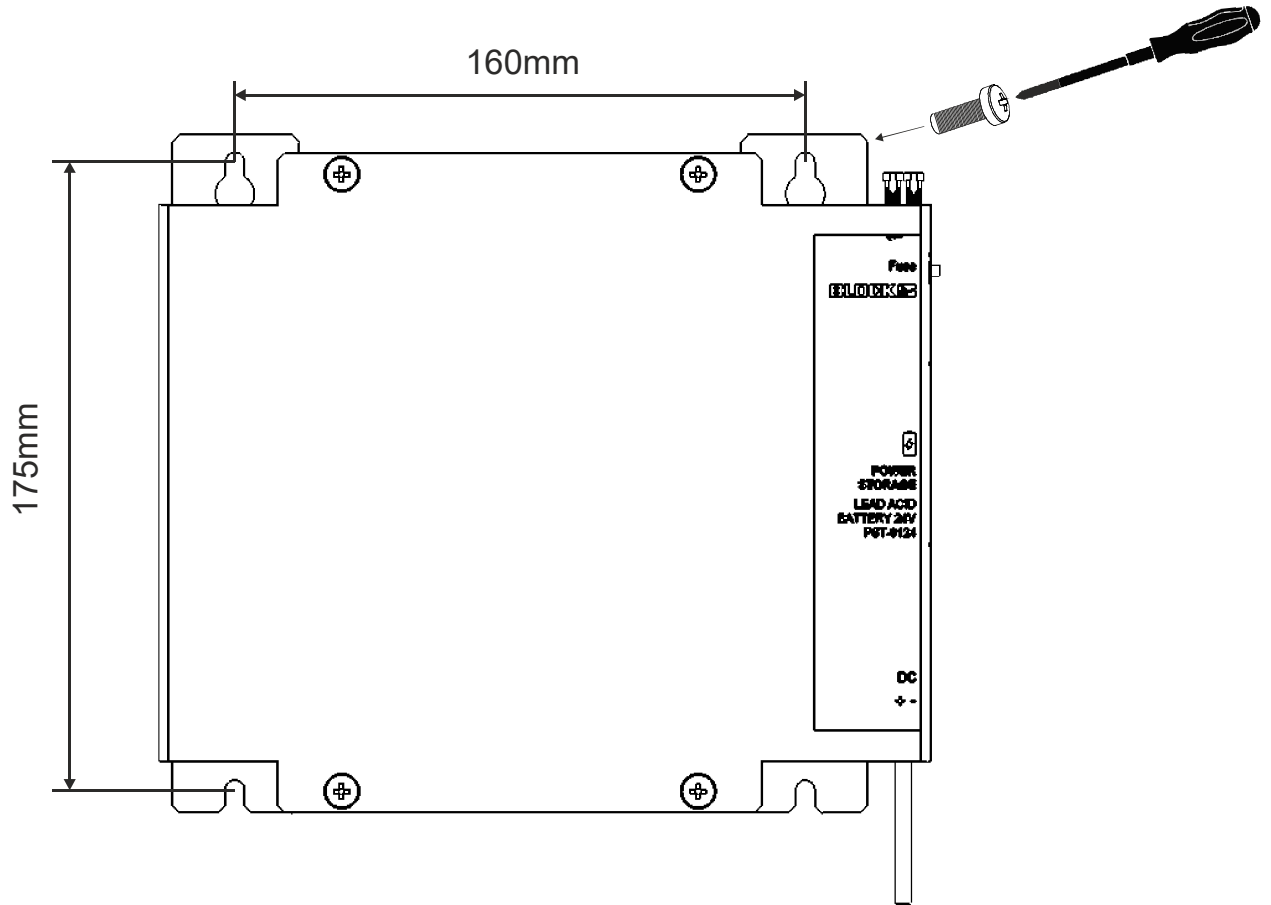

Figure 7: Assembly



#### ATTENTION

It is not permitted to mount the battery modules upside down on the cover side of the housing, see the following illustrations.

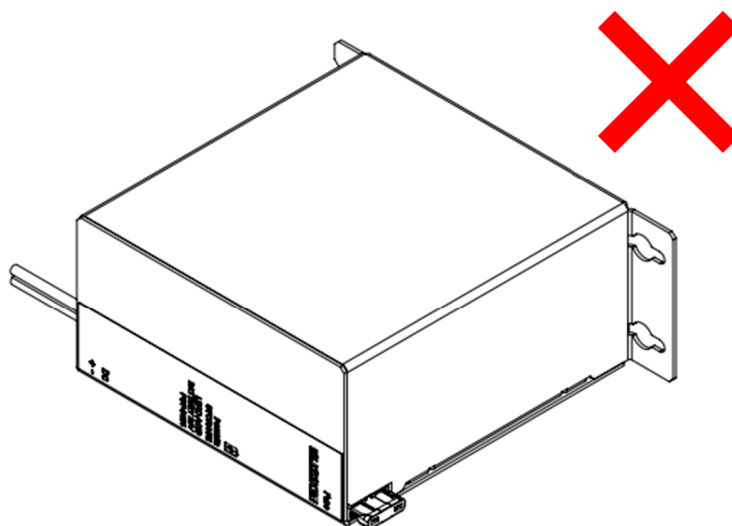

Figure 8: PST-0124-032-00

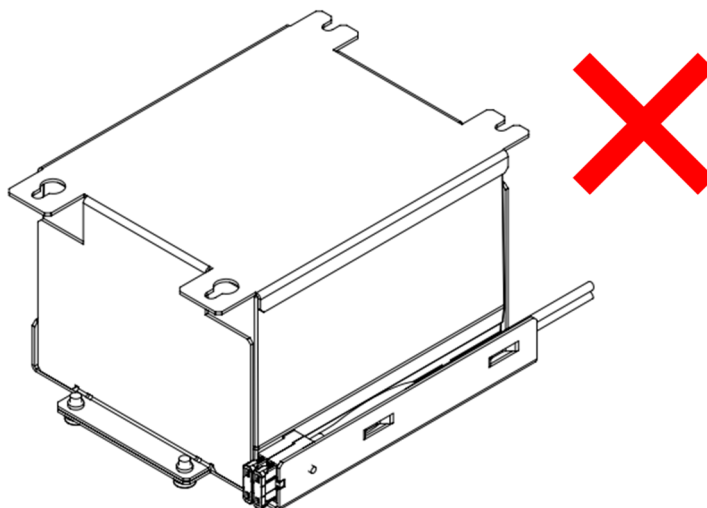

Figure 9: PST-0124-070-00

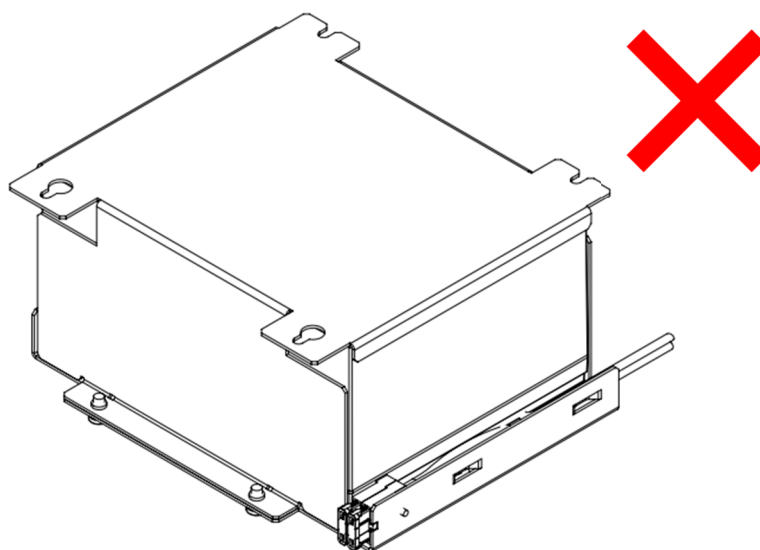

Figure 10: PST-0124-120-00

## 4. Commissioning



### NOTE

After the battery module has been installed on the charging and control unit, the fuse must be inserted into the fuse holder

### 4.1 Battery

Max. charging voltage and charging current

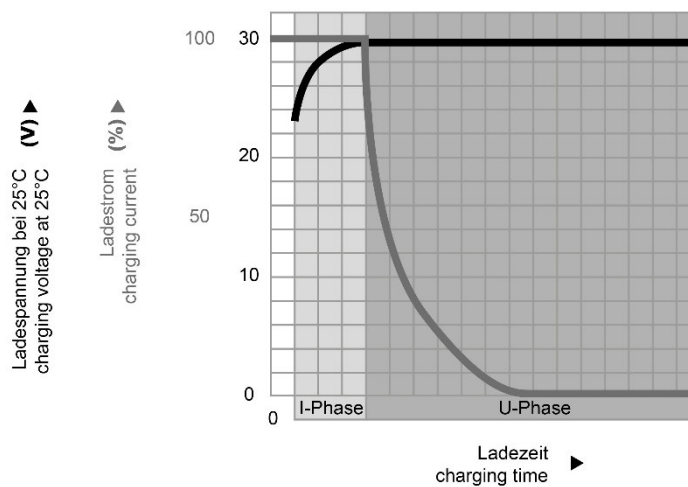

Figure 2: Charging characteristics

Step	Name	Description
1	Main cargo	Constant current charging phase initial charging current
2	Equalization Charge / Trickle Charge	Constant voltage charging phase Compensating charging closing voltage Trickle charge end voltage

To ensure temperature compensation, the temperature recorded in the loading and control unit is used as an alternative.



### NOTE

The temperature compensation for battery modules without "Battery Control" is treated as in the case of a communication interruption. Depending on the UPS used, changes can only be made via the UPS Control software or via the front potentiometers.

## 4.2 Buffer times of the battery modules

The following graphic shows the maximum possible buffer times of the battery modules. The buffer times symbolize typical average values and result from battery modules in mint condition after they have been fully charged.

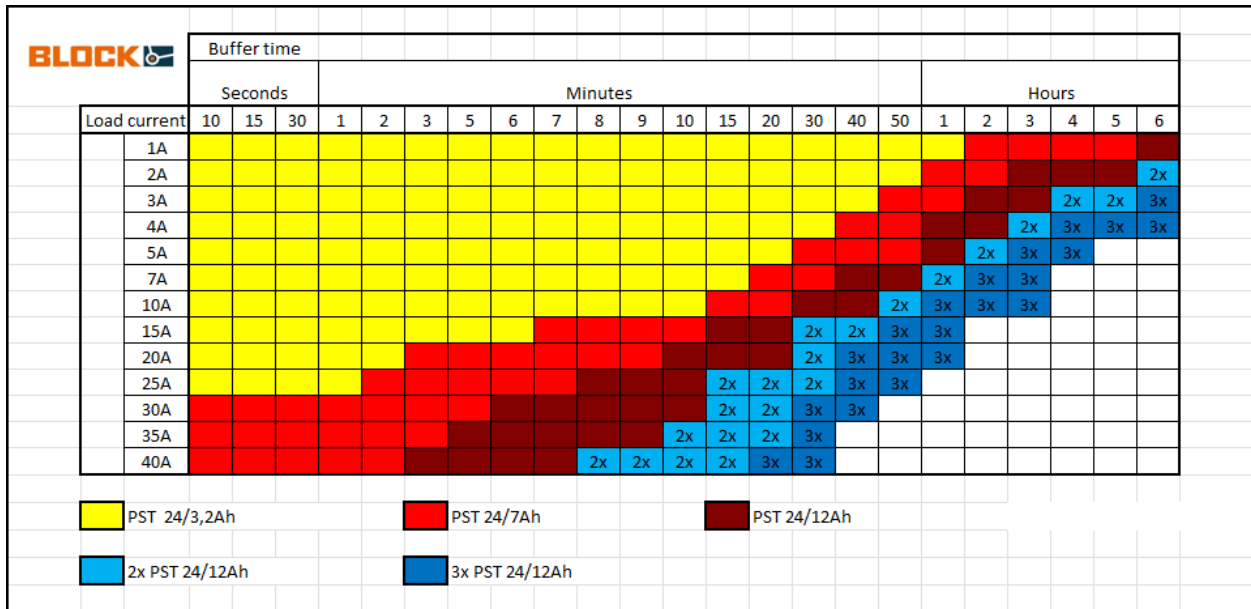

The buffer time can be extended by up to three battery modules connected in parallel. It should be noted that only the same battery modules with the same state of charge may be connected.

## 5. Maintenance

### 5.1 Battery module life

The battery modules of the PST series are equipped with sealed, maintenance-free lead fleece batteries that are designed for -10 °C to +40 °C. The service life of these battery modules is between 5 years at 20 °C and one year at 40 °C, depending on the ambient temperature.

### 5.2 Storage of the battery modules

The battery modules are delivered pre-charged to ensure immediate availability. The date of the last recharge is listed on the packaging. The latest start-up should take place after 9 months at 20 °C - 30 °C or after 6 months at 30 °C - 40 °C after the last charge.

**ATTENTION:**

Please disconnect the battery modules before updating the firmware. After updating, you can reconnect the battery modules and reset the battery voltage setpoint

**ATTENTION:**

In 24 V operation, it is not allowed to connect a 12 V battery module. This can lead to the destruction of the battery module.

**ATTENTION:**

The battery modules must not be stored overhead when switched off.

**ATTENTION:**

When shipping or storing the UPS system, the associated device fuse must be removed to protect the battery modules from discharge.

## 6. Disposal and Recycling



### Ensure proper disposal of electronic components

Do not dispose of the power supply with household waste.

Observe the applicable national regulations.

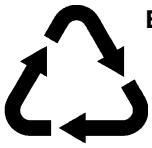

### Ensure proper disposal or recycling

Dispose of or recycle packaging material that is no longer required with household waste.

Observe the applicable national regulations.