

# MANUAL

Uninterrupted  
Power Supply

Charging and control unit  
**PC-0524-400-0**



# Table of contents

<b>1. ... Ordering data .....</b>	<b>3</b>
<b>2. .. GENERAL INFORMATION.....</b>	<b>4</b>
2.1 Safety.....	4
2.2 Qualified personnel .....	4
2.3 Intended use .....	4
2.4 Disclaimer.....	4
<b>3. .. PRODUCT DESCRIPTION .....</b>	<b>6</b>
3.1 Block diagram .....	7
3.2 Dimensioning.....	8
3.3 Assembly.....	9
3.4 Connections and signalling .....	11
<b>4. .. COMMISSIONING .....</b>	<b>12</b>
4.1 Operating states/ signalling .....	12
4.2 Battery Testing .....	15
4.3 Battery charging .....	17
4.4 Battery.....	19
4.5 Buffer times of the battery modules.....	22
4.6 Derating .....	23
<b>5. .. MAINTENANCE .....</b>	<b>24</b>
5.1 Battery module life .....	24
5.2 Storage of the battery modules.....	24
<b>6. .. USV FIRMWARE UPDATE.....</b>	<b>24</b>

## 1. Ordering data

The table shows the order data of the charging and control unit and the battery modules.

Table 1: Order numbers

<b>Charging and control unit</b>			
<b>Variant</b>	<b>Input voltage</b>	<b>Output current</b>	
<b>PC-0524-400-0</b>	24 Vdc	40 A	
<b>BATTERYMODULES</b>			
<b>Variant</b>	<b>Input voltage</b>	<b>Output current</b>	<b>Capacity</b>
<b>PVAF 24/0,8 Ah</b>	24 Vdc	max. 5 A	0,8 Ah
<b>PVAF 24/1,2 Ah</b>	24 Vdc	max. 7,5 A	1,2 Ah
<b>PVAF 24/7 Ah</b>	24 Vdc	max. 40 A	7 Ah
<b>PVAF 24/12 Ah</b>	24 Vdc	max. 40 A	12 Ah
<b>PVA 24/3,2 Ah</b>	24 Vdc	max. 20 A	3,2 Ah
<b>PVA 24/7 Ah</b>	24 Vdc	max. 40 A	7 Ah
<b>PVA 24/12 Ah</b>	24 Vdc	max. 40 A	12 Ah
<b>PST-0124-032-00</b>	24 Vdc	max. 20 A	3,2 Ah
<b>PST-0124-070-00</b>	24 Vdc	max. 40 A	7 Ah
<b>PST-0124-120-00</b>	24 Vdc	max. 40 A	12 Ah

### UPS-Control Software

Visualization and configuration software for the charging and control unit. Free download at [www.block.eu](http://www.block.eu).  
For the display and individual setting of the loading and control unit.

## 2. GENERAL INFORMATION

### 2.1 Safety

Please read these warnings and safety instructions carefully before using the device. The device may only be installed by competent and qualified personnel. In the event of malfunctions or damage, immediately switch off the supply voltage and send the device to BLOCK Transformatoren-Elektronik GmbH for inspection. The device does not include any service components. If an internal fuse is tripped, there is most likely an internal defect in the device. The data provided are for product description purposes only and are not to be regarded as warranted properties in the legal sense.

### 2.2 Qualified personnel

The product associated with this documentation may only be handled by qualified personnel in compliance with the documentation related to the respective task, in particular the safety and warning instructions contained therein. Qualified personnel can guarantee on the basis of their training and experience that the use of the described product meets all safety requirements as well as the applicable regulations, regulations, standards and laws.

### 2.3 Intended use

This device is designed to be installed in an enclosure and is suitable for use with general electronic devices, such as industrial controls, office equipment, communication equipment or measuring instruments. Do not use this device in control systems of aircraft, trains or nuclear facilities where malfunction could result in serious injury or danger to life.

### 2.4 Disclaimer

The content of this publication has been checked with the greatest care for compliance with the hardware and software described. Nevertheless, there may be discrepancies between the product and the documentation. Deviations can also occur due to the constant further development of the product. For this reason, we cannot guarantee complete compliance. If this documentation contains errors, we reserve the right to make necessary corrections without prior notice.



**ATTENTION**

Switch off the input voltage before installation, maintenance or modification work and protect it against unintentional reconnection.



**ATTENTION**

Do not make any modifications or repair attempts to the device. Do not open the device!



**ATTENTION**

Prevent the ingress of foreign objects, such as paper clips and metal parts.



**ATTENTION**

Do not operate the appliance in a humid environment or in an environment where condensation or condensation.



**ATTENTION**

Do not touch the housing during operation or shortly after shutting down. Hot surfaces can cause injuries.

### 3. PRODUCT DESCRIPTION

The charging and control unit forms an uninterruptible power supply (UPS) in combination with up to three battery modules and a suitable external power supply. This UPS protects the system and sensitive data from mains failures and voltage fluctuations. Depending on the application, up to 40 A is therefore available without interruption for 12 V and 24 V networks. The charging and control unit always ensures a safe supply of industrial PCs.

The intelligent battery management of the UPS combines short charging times with optimized charging management for the longest possible service life of the battery modules. In addition, permanent monitoring of the battery modules is available, which provides early warning if the battery modules have little remaining service life.

A special feature of the device is the setting option via the rotary switch attached to the front. This rotary switch allows a fixed buffer time, individual configuration via the interface (only in conjunction with the UPS Control software) or the IPC shutdown mode to be selected.



Figure 1: Loading and control unit

### 3.1 Block diagram

The following block diagram shows a wiring example.

To ensure good communication between the battery modules and the charging and control unit, interface, control and signal cables < 3 meters must be selected.

In addition, care must be taken not to lay the control cable parallel to power lines, otherwise disturbances in communication are to be expected.

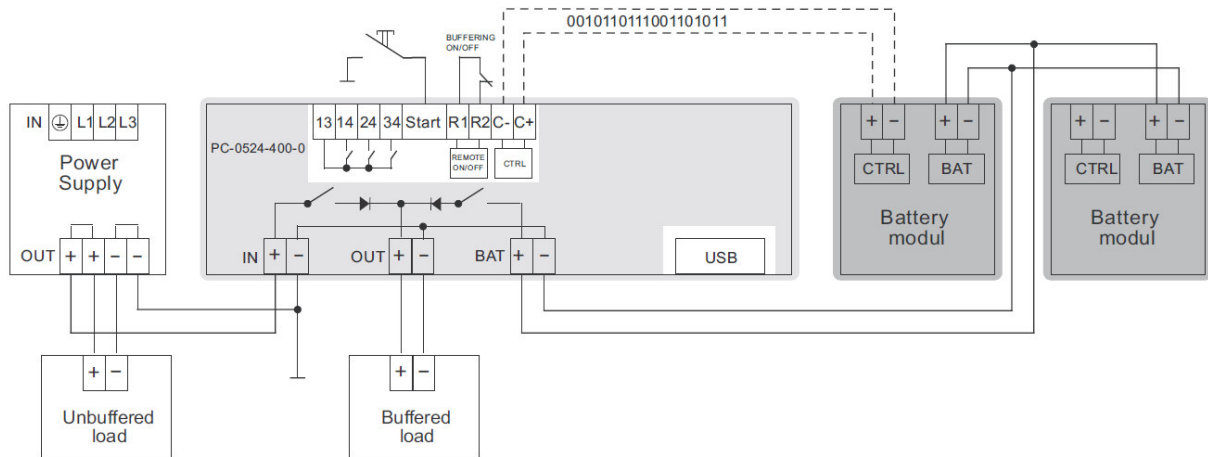

Figure 2: Wiring block diagram

In order to obtain the maximum buffer time, it is possible to connect up to 3 battery modules in parallel (see chapter 4.5).

If several battery modules are used, the control cable must be attached to only one battery module.

### 3.2 Dimensioning

The dimensions of the loading and control unit can be seen in Figure 3.

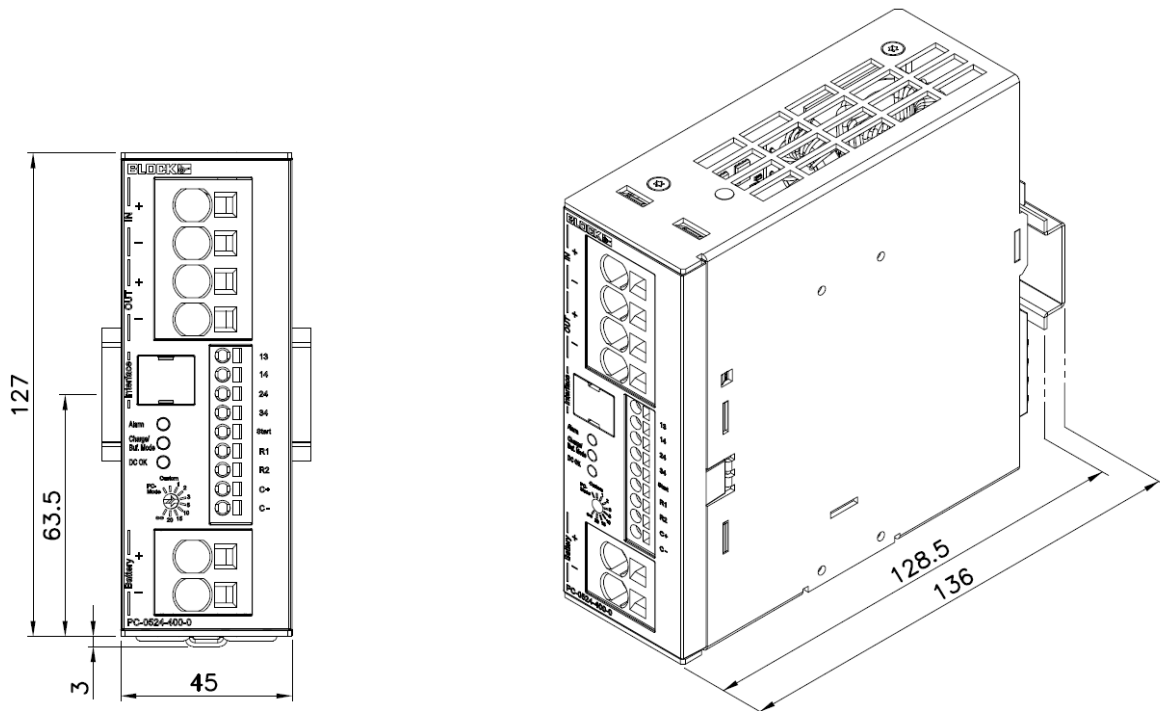

Figure 3: Dimension of the Loading and Control Unit

The dimensions of the corresponding battery modules can be found in the operating instructions for the battery modules.



### 3.3 Assembly

The loading and control unit can be mounted on the DIN rail without tools.

To do this, the front of the device is first turned slightly upwards and placed on the DIN rail. It should be noted that the device is pushed down to the stop. When the device sits on the DIN rail, the underside is pressed against the mounting rail until it is locked in the DIN rail (followed by a "click" sound). To check, shake the device again lightly to ensure proper locking.

A standard tool, such as a flat-head screwdriver, is required for disassembly. By pressing down the fastener, the device can be detached from the DIN rail by lifting the underside of the device.

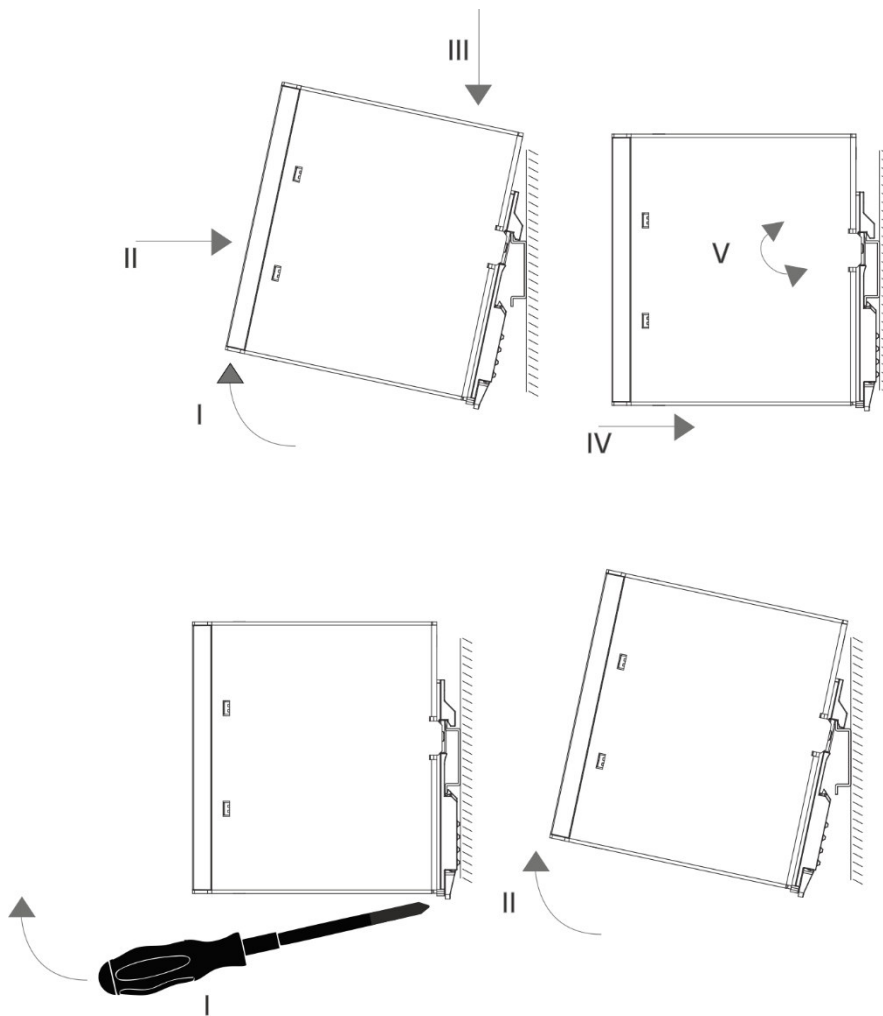

Figure 4: Assembly



#### ATTENTION

Mounting the battery modules overhead is not permitted.

To ensure cooling by natural convection, a distance of at least 40 mm from neighboring devices must be maintained at the bottom and top. Direct lateral mounting of other devices is permitted.

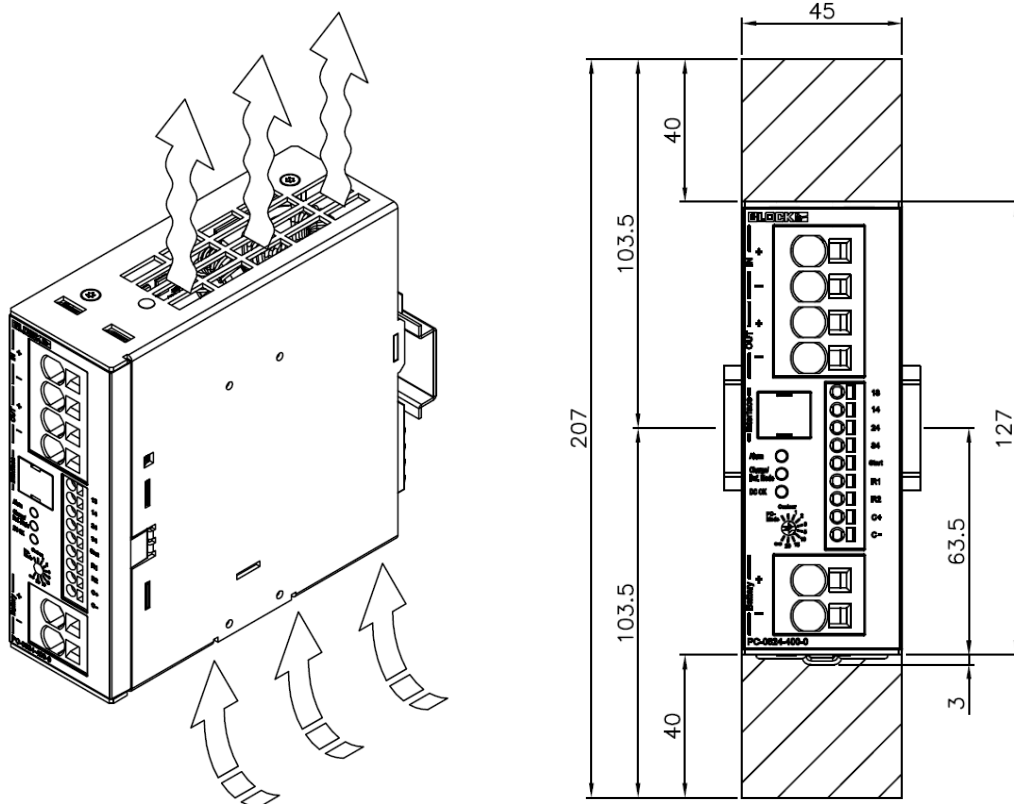

Figure 5: Convection cooling



**ATTENTION**

Mount the device horizontally only. A different assembly is not permitted.

### 3.4 Connections and signalling

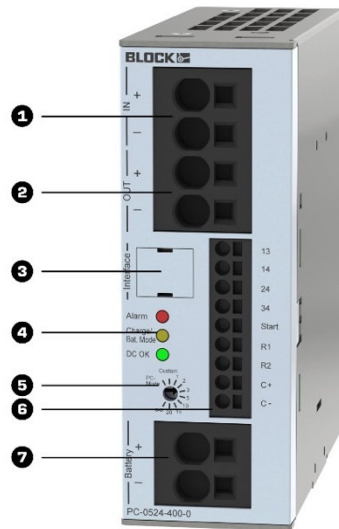

Nr.	Function	Note
1	Power supply input terminals	0,75 – 16 mm <sup>2</sup> (20...4 AWG)
2	Power supply output terminals	0,75 – 16 mm <sup>2</sup> (20...4 AWG)
3	PC interface	USB Interface Connector (USB Type B)
4	Indicators	LED rot: Alarm LED yellow: Bat. Charge /Bat. Fashion LED grün: DC OK
5	Rotary switch for buffer time setting	Buffer time in minutes (1-20) IPC-Modus (PC-Mode) Maximum Time (∞) Individual Time (Custom)
6	Signal and signaling contacts	13: Potential-free collective input for signal outputs 14/24/34 14: Alarm (default = active low) 24: Battery Mode (default = aktive high) 34: Battery Charge (default = aktive high) Start: Start-up in battery mode R1/R2: Remote shutdown in the Buffering C+/C-: Control cable for „Battery Control“ 0,2-2,5 mm <sup>2</sup> (24...12 AWG)
7	Battery terminals	0,75-16 mm <sup>2</sup> (20...4 AWG)

## 4. COMMISSIONING

After connecting battery modules with "Battery Control", they are automatically detected, provided that the control cable "C+/C-" is connected for communication between the modules with the correct polarity.

### 12 V operation

The charging and control unit is suitable for both a nominal voltage of 12 V and 24 V (delivery state). To activate the 12 V operation, a connection with the UPS Control software is required. The 12 V operation must first be activated for the connected device via the UPS control. The setting option for activation can be found in the "Parameters" tab under "Advanced settings".

For 12 V operation, a stand-alone 12 V battery module is required. The use of the 24 V battery modules is not possible in this mode.



#### ATTENTION

With connected 12 V batteries, switching to 24 V operation can lead to the destruction of the battery modules.



#### NOTE

For optimal supply of the battery modules, operation with connected Control cables and battery modules with "Battery Control" recommended. The polarity must be observed. Before the module is powered, the battery modules should be fully connected to avoid false signaling.

### 4.1 Operating states/ signalling

The charging and control unit can signal current operating states, warnings and faults. Three indicator lights (LED) and three potential-free contacts are available for function monitoring.

When delivered, the signal outputs are configured as follows:

Table 1: Configured Signal Outputs

Condition	Signal Output	Function
No battery operation possible or battery replacement recommended or output switched off	13/14	Non-inverted
UPS works on battery power	13/24	Inverted
Charging the battery module	13/34	Inverted

The charging and control unit is able to detect several events that can be individually linked to the three signal outputs via the UPS-Control configuration and management software. The logic (inverted / non-inverted or low-impedance / high-impedance) can also be changed if necessary

Table 2: Detectable Events

Nr.	Description
1	Buffering
2	No buffer operation possible: Presence test negative or connection for remote shutdown (remote input) not available
3	Battery voltage very low < 20,4 V
4	Battery charge < 85 %
5	Battery replacement recommended
6	Output is off
7	Fuse-Mode
8	Hiccup-Mode
9	Output current too high
10	Temperature monitoring
11	System failure
12	Safety shutdown

The charging and control unit has three overload behaviors that can be selected.

#### *Hiccup Mode*

The output cannot be ramped up within 5 seconds due to a short circuit or continuous overload. There are 3 start-up attempts with a waiting time of 20 seconds each. If there has been no restart so far, a 5-minute break is carried out before the next attempt.

#### *Fuse Mode*

The output cannot be ramped up within 5 seconds due to a short circuit or continuous overload. The output remains switched off.

To exit Fuse Mode, the "Reset Fuse Mode" button must be pressed. This appears in the UPS Control software in the "Overload Behavior" section as soon as the Fuse Mode is activated.

If the restart has been unsuccessful, it can only be tried again after a waiting time of 20 seconds.

#### *Power Boost/Top Boost*

If an overload occurs, the charging and control unit with the Power Boost makes it possible to supply temporarily increased loads.

- Without Boost : 45A for 3mS
- PowerBoost : 45A for 5mS
- TopBoost : 45-65A for 55mS, then 45A for 5S

The Power Boost in mains mode must be supported by the upstream power supply.

#### **NOTE**



Hiccup mode is activated in the state of delivery. To activate the Fuse Mode or the Power Boost, the UPS Control software is required. In the UPS Control software, the Fuse Mode or the Power Boost can be selected under the tab "Parameters" and "Overload Behavior".

The LED status indicators also show the operating status of the charging and control unit. The light signals have the following meaning.

Table 3: Signaling via LED status indicators

Operating status	LED green	LED yellow	LED red
	DC OK	Charge/Bat. Mode	Alarm
UPS works in normal operation Output voltage > 20.4 V Battery is charged and OK	On	Off	Off (Flashes (1 Hz) Battery replacement recommended)
UPS works in normal operation Charging the battery (Charge < 85% of rated capacity)	On	On	Off (Flashes (1 Hz) Battery replacement recommended)
UPS works in normal operation, no battery operation possible (Presence test negative or remote shutdown R1/R2 active)	On	Off	On
UPS works in normal operation Battery replacement recommended	On	Off	Flashes (1 Hz)
UPS works in the Buffer mode/IPC mode Battery voltage > 20.4 V	On	Flashes (1 Hz)	Off (Flashes (1 Hz) Battery replacement recommended)
UPS works in the Buffer mode/IPC mode Battery voltage < 20.4 V Device shortly before shutdown	On	Flashes (4 Hz)	aus (blinkt (1 HZ) Akkutausch empfohlen)
UPS Deep Discharge Protection Buffer operation is terminated (Factory setting battery voltage < 18 V)	Off	Flashes (4 Hz)	Flashes (1 Hz)
Safety shutdown (No buffer operation possible or remote shutdown R1/R2 active or no battery connected)	Flashes (1 Hz)	Off	On
Safety shutdown (Input voltage too small or too large, output switched off)	Flashes (1 Hz)	Off	Off
UPS is in Hiccup Mode	Off	Off	Flashes (1 Hz)
UPS is in Fuse Mode	Off	Off	Flashes (4 Hz)
Shutdown Mode IPC shut down/wait time	Off	Off	On

### Safety shutdown

The output is switched off to protect the charging and control unit and consumption. If a voltage that is too low < 18 V / 9 V for 24 V / 12 V operation or too high a voltage > 30 V / 15 V for 24 V / 12 V operation is detected during the switch-on process, the nominal voltage is waited for the nominal voltage to return within a waiting period of 60 seconds. If no change in voltage is detected after the waiting time has elapsed, the system switches to shutdown mode.

### *Shutdown Mode*

The shutdown mode has been activated due to the safety shutdown.

If the mains voltage does not fall below 3 V within 5 seconds, it switches back to safety shutdown. If the mains voltage does not reach the nominal voltage after three runs, the waiting time in shutdown mode is extended to 120 seconds.

Buffer operation has been terminated (buffer time has expired or buffer operation has been terminated due to deep discharge protection) and the mains voltage is not in the rated range. The red LED signals this state for another 5 seconds, after which the system is switched off.

### *Start from the battery*

If an external start of the system is required without an attached power supply, the charging and control unit allows the system to be started from the connected battery. By briefly applying 0 V to the "start" terminal, the charging and control unit is started in buffer mode and the connected load is supplied entirely from the connected batteries.

If the mains voltage is present after the system has been started, the charging and control unit automatically switches to normal operation.



#### **ATTENTION**

The application of 0 V to the "start" terminal must only be done for a short time (impulse), because if 0V is permanently applied to the "start" terminal, the safety shutdown is bypassed.

#### **NOTE**

In the state of delivery, the statuses of the LED displays are also signaled at the same time via the signal outputs. If the signal outputs are individually assigned, signal states that deviate from the LED display are possible. Make sure that only sensible combinations are signaled.

## **4.2 Battery Testing**

The charging and control unit performs different checks on the battery modules depending on the operating status. If irregularities are detected, appropriate warnings or disruptions are generated.

### *Status Charging*

In normal operation, the battery module is charged. During charging, the state of charge is checked every 60 seconds.

If the battery modules are charged < 85%, the "Battery is charging" status is signalled. The yellow LED lights up as well as the signal output "Bat. Charge" is activated (only in the delivery state).

### *Classroom test*

The presence test is used to detect a correctly connected and functional battery module and is carried out in normal operation. During the presence test, the battery modules are subjected to a slight load for a short time to ensure that the battery module is connected correctly, that the batteries are functional and that the fuse is intact.

The presence test is carried out in normal operation with a charging current  $< 1$  A every 30 seconds and a charging current  $> 1$  A every 180 seconds. In the event of a negative result, the test is repeated cyclically every 15 seconds.

If the presence test yields a negative result, the fault "no buffer operation possible" is signaled. The red LED lights up and the "Alarm" signal output is activated (only in the delivery state).



**NOTE**

For battery modules without "Bat. Control", only the presence test takes place.



**NOTE**

The presence test is carried out every 60s

### *Quality test*

Accumulators have a limited lifespan, which can range from  $< 1$ -15 years, depending on the model and depending on the ambient temperature.

The remaining service life of the batteries is dynamically calculated depending on the ambient temperature in the battery module, provided that both "Bat. Control" control cables are connected correctly. This check is carried out every 10 minutes during normal operation. If the quality test yields a negative result, the warning "Battery replacement recommended" is generated. The red LED will flash and the "Alarm" signal output will be activated.



**NOTE**

It is recommended to reinstall the battery module as soon as possible after the warning occurs. in order to maintain secure buffer operation.



### 4.3 Battery charging

Intelligent battery management enables dynamic adjustments such as setting the optimal charging current or a temperature-dependent charging voltage for all detected battery modules with "Battery Control".

#### Temperature-dependent charging voltage

By measuring the real temperature directly in the battery module with "Battery Control", the charge is temperature-compensated. The service life of the installed batteries is thus sustainably extended. Further settings of charging parameters are not necessary due to the automatic detection.

The charge control is based on an IU charging characteristic. This is a 2-stage charging process, which is as follows.

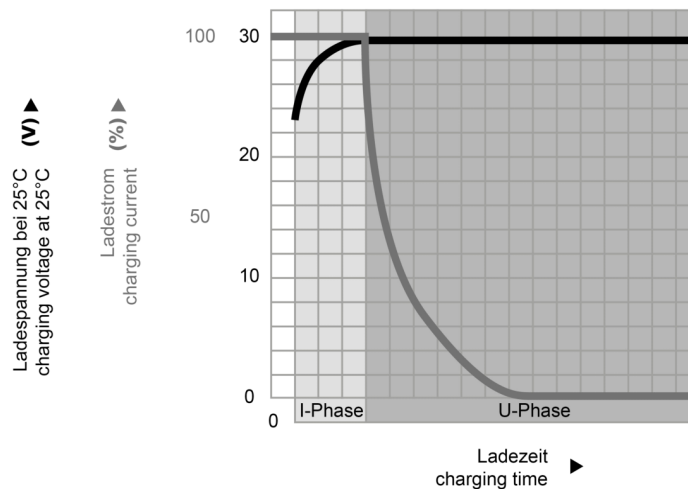

Figure 6: Charging characteristics

Step	Name	Description
1	Main cargo	Constant current charging phase initial charging current
2	Equalization Charge / Trickle Charge	Constant voltage charging phase Compensating charging closing voltage Trickle charge end voltage

In the event of interruptions in the communication cable between the charging and control unit and the battery module, the temperature recorded in the charging and control unit shall be used as a substitute to ensure temperature compensation.



#### NOTE

The temperature compensation of battery modules without "Battery Control" is treated as if there were a communication interruption.

If battery modules are used without communication, the adjustment of general charging parameters must be checked and ensured individually depending on the battery module used.

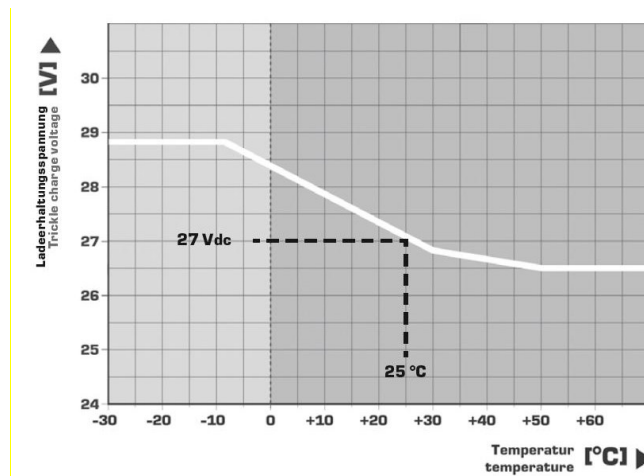

Figure 7: Compensation charging characteristic curve

Automatic temperature compensation can be deactivated at any time via the configuration software. A fixed value for the final float voltage can be stored individually.

**NOTE**



In order to enable temperature-dependent charging even for battery modules without "Battery Control", it is possible to attach a separate temperature sensor to the battery module and connect it to the charging and control unit via the terminals "C+" and "C-". In order to obtain accurate measurement results, it is necessary to use only the following Temperature sensor to use:

*Factory Charging Setting*

After detecting the battery modules with "Battery Control", subsequent charging settings are adopted at the factory. Battery modules without "Battery Control" are charged at the factory with a voltage of 27.4 V / 13.7 V in 24 V / 12 V operation and a charging current of 0.8 A.

Table 4: Factory Charging Setting Variant	Charging voltage	Charging current
PVAF 24/0,8Ah	28,8 V	0,2 A
PVAF 24/1,2 Ah	28,8 V	0,3 A
PVAF 24/7 Ah	28,8 V	1,8 A
PVAF 24/12 Ah	28,8 V	3,0 A
PVA 24/3,2 Ah	28,8 V	0,8 A
PVA 24/7 Ah	28,8 V	1,8 A
PVA 24/12 Ah	28,8 V	3,0 A

**NOTE**



The configuration software can be used at any time to set an individual charging current as set point, regardless of the battery module used.

## 4.4 Battery

In the event of a failure of the mains voltage, buffer operation is switched to without interruption. The energy required to maintain the DC 24 V / 12 V supply voltage is taken from the battery module. The level of the output voltage is directly dependent on the state of charge and the capacity of the batteries.

Buffer operation is signaled by the slow flashing of the yellow LED (approx. 2 Hz). Ex-works, this event is marked with the signal output "Bat. Fashion".

The charging and control unit supports both the maintenance of the supply voltage for a configurable time and the controlled shutdown and restart of an industrial PC (IPC) – see chapter "Buffer operation in IPC mode".

To shut down an IPC on the software side, the rotary switch must be set to "PC Mode" or the setting via the Windows software "UPS-Control" is possible. If the charging and control unit is connected to the IPC, the cyclically transmitted data from the UPS triggers the shutdown after an adjustable time.



### ATTENTION

In 24 V operation, it is not allowed to connect a 12 V battery module. This can lead to the destruction of the battery module.

#### *Switching threshold for buffer operation*

If the input voltage drops below the switching threshold, the energy from the battery modules is provided without interruption. The charging and control unit is then in buffer mode.

The activation threshold is preconfigured to 22 V ex works. The activation threshold can be changed via the UPS-Control configuration software.

21 V - 26 V adjustable (24 V operation)  
10.5 V - 13 V adjustable (12 V operation)

#### *Buffer operation with adjustable buffer time*

The module is preconfigured for maximum (unlimited) buffer time ex works. In this configuration, all the energy of the battery module is used to maintain the DC 24 V supply voltage. The buffer time can be set via the selector switch.

1 ... 20 minutes  
Unlimited until deep discharge protection stops buffering  
Individual time via configuration software  
PC Mode, see chapter "Buffer Operation in IPC Mode"

### *Buffer operation in IPC mode*

In IPC mode, the UPS module works according to a chronological sequence that serves the controlled shutdown and reliable restart of an IPC. Changeable times can only be adjusted via the configuration software. The signal for shutting down the IPC is transmitted via the potential-free signal contact selected in UPS Control.

The chronological sequence of "delay time", "shutdown time" and "waiting time" is defined in each case. Due to the possibility of switching off the output despite mains return during buffer operation, an IPC can be reliably restarted after shutdown.



#### **NOTE**

To activate IPC mode, the rotary switch on the charging and control unit must be set to PC mode. Only then does the IPC configuration appear in the UPS Control software.

### *Delay*

If the mains voltage returns during the set delay time in buffer mode, the output of the charging and control unit is not switched off.

The signal output "Bat. Mode" (can be configured via the configuration software) remains in the inactive state, so that no signal is generated for a shutdown of the IPC.

If the input network does not return until after the set delay time has elapsed, the output voltage and signal output are switched according to the flow diagram.

5 - 65,535 seconds adjustable

#### *Disconnecting time*

After the delay time has elapsed, the signal output "Bat. Mode" is activated. This signal output remains in the activated state for the entire set time. Thus, the IPC receives the request to shut down. During the entire set time, the IPC will continue to be powered by the charging and control unit.

0 - 65,535 seconds adjustable

### *Latency*

After the shutdown time has elapsed, the output voltage is switched off if the input voltage is available again between the end of the delay time and the beginning of the waiting time. This gives the IPC the necessary 0 – 24 V edge for a restart after the PC idle time has expired.

If the input voltage is not yet available again after the shutdown time has expired, the charging and control unit including the output is permanently switched off. After the module has been switched off, an automatic restart takes place only by returning the input voltage with the DC 24 V switching on at the output.

0 - 65,535 seconds adjustable

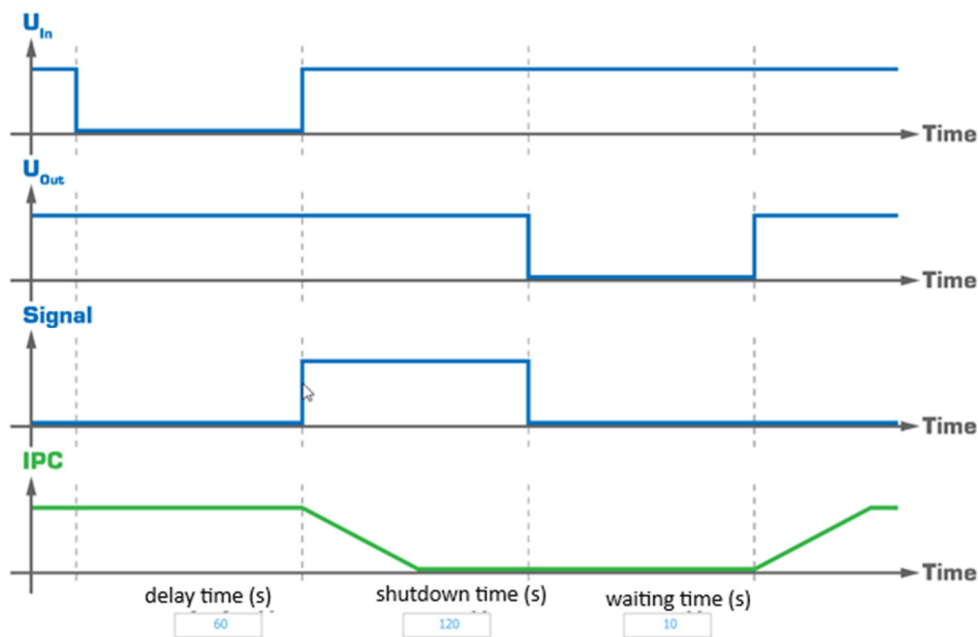

Figure 8: IPC Setting

#### Remote shutdown in buffer mode

If the connected load at the output of the charging and control unit is not to be supplied from the battery module during buffer operation, e.g. in EMERGENCY STOP mode, the buffer mode can be disabled. To do this, the connection between the two contacts R1/R2 of the "remote" input must be interrupted.

If this connection is not available during normal operation, the module signals the fault "no buffer operation possible". The red LED lights up continuously. This interference is linked to the "Alarm" signal output ex works, so that the contact is opened.

#### Deep discharge protection in buffer mode

In order to protect the installed battery modules against deep discharge, the buffer operation is forcibly terminated at a battery voltage  $U_{bat} < 18\text{ V} / 19.2\text{ V} / 9\text{ V} / 9.6\text{ V}$  (deep discharge threshold adjustable) in  $24\text{ V} / 12\text{ V}$  operation. The module switches off the output.

The signaling by the flashing LEDs is maintained in the voltage range  $U_{bat} < 19.2\text{ V} / 9.6\text{ V}$  in  $24\text{ V} / 12\text{ V}$  after switching off the output before the module switches off completely after the voltage  $U_{bat} < 18\text{ V} / 9\text{ V}$  in  $24\text{ V} / 12\text{ V}$  is dropped. After the output has been switched off, the output is only reconnected when the input voltage returns.

From a battery voltage  $< 20.4\text{ V} / 10.2\text{ V}$  in  $24\text{ V} / 12\text{ V}$  operation, the module signals the warning "Battery is almost empty" by flashing the yellow LED at 4 Hz.

### 4.5 Buffer times of the battery modules

The following graphic shows the maximum possible buffer times of the battery modules. The buffer times symbolize typical average values and result from battery modules in mint condition after they have been fully charged.

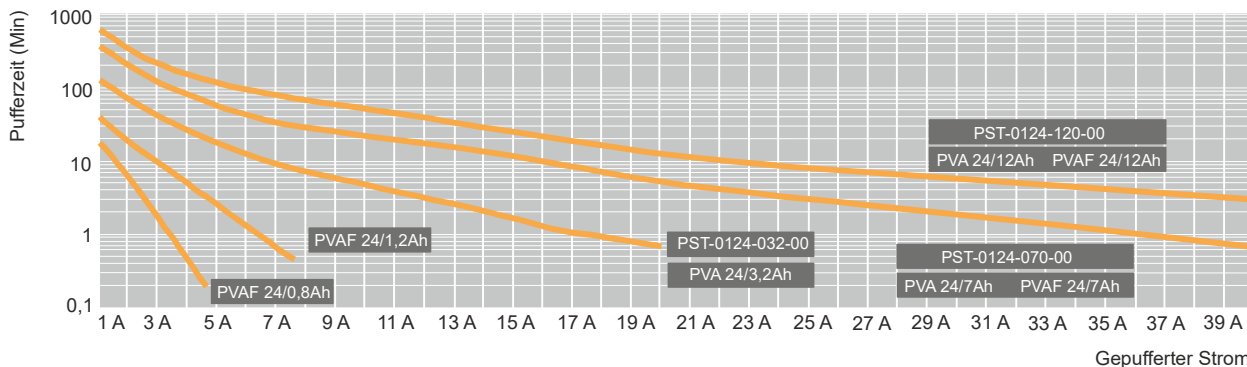

Figure 9: Battery module buffer times

The buffer time can be extended by up to three battery modules connected in parallel. It should be noted that only the same battery modules with the same state of charge may be connected.

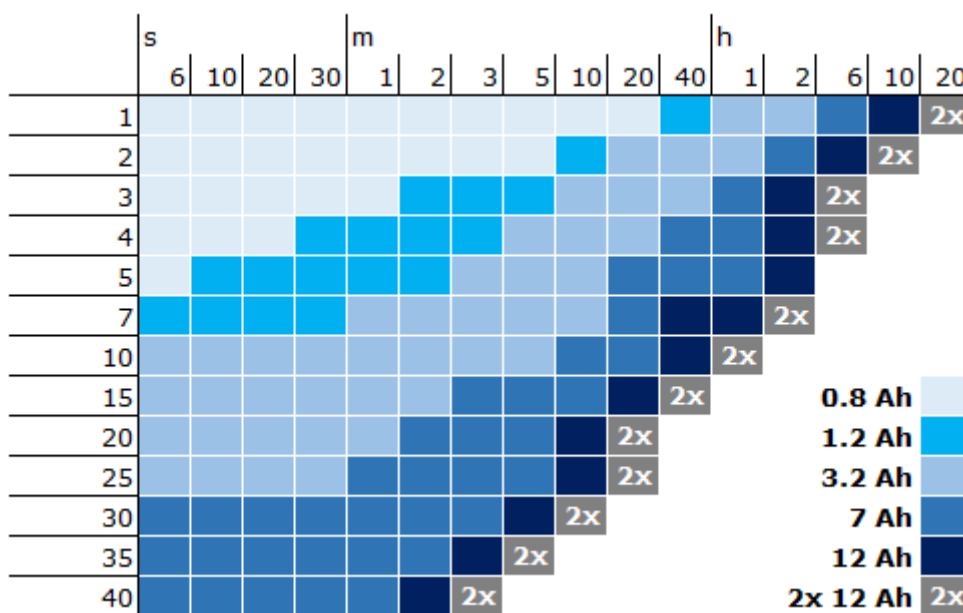

Figure 10: Buffer time as a function of the load current

## 4.6 Derating

The functionality of the charging and control unit is designed for a wide temperature range. To protect the charging and control unit, the power should be reduced from a temperature of 60 °C to prevent the device from overheating.

The maximum output current is provided up to a temperature of 60 °C. In addition, the rated output current per Kelvin must be reduced by 2.5%.

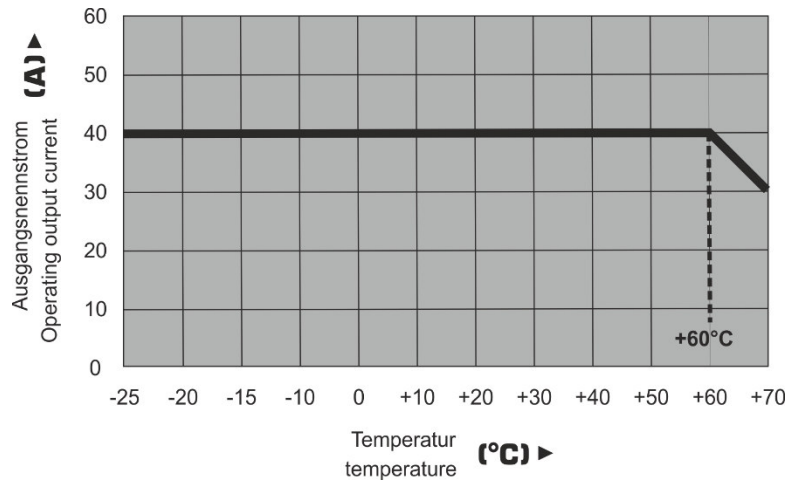

Figure 11: Temperature behavior of the rated output current

The maximum charging current is provided up to a temperature of 50 °C. In addition, the charging current per Kelvin is reduced by 3%.

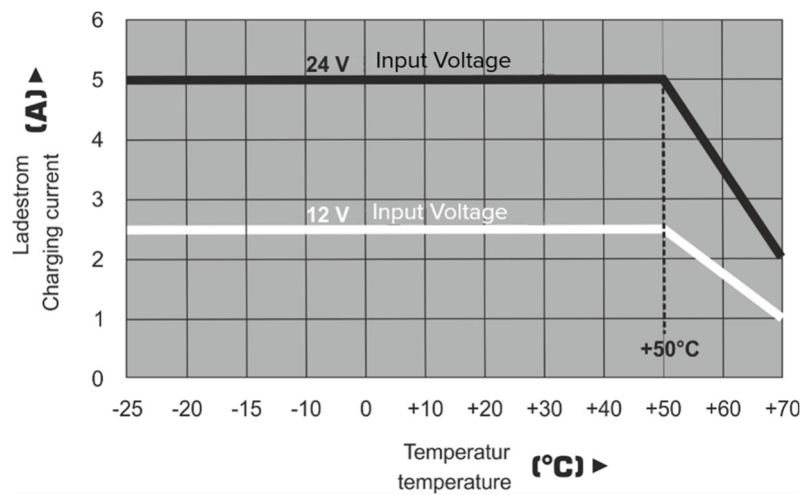

Figure 12: Temperature behavior of the charging current

## 5. MAINTENANCE

### 5.1 Battery module life

The battery modules of the PVA, PVAF and PST series are equipped with sealed, maintenance-free lead fleece accumulators that are designed for -10 °C to +40 °C. The service life of these battery modules is between 5 years at 20 °C and one year at 40 °C, depending on the ambient temperature.

The remaining service life is dynamically calculated depending on the ambient temperature of the battery module, provided that both control lines are connected between the charging and control unit and the battery module. In addition, the battery modules are cyclically loaded to detect the exceeding of a permissible voltage drop. This allows conclusions to be drawn about accumulators that have already been damaged even before the end of their service life.

### 5.2 Storage of the battery modules

The battery modules are delivered pre-charged to ensure immediate availability. The date of the last charge is listed on the packaging. The latest start-up should take place after 9 months at 20 °C - 30 °C or after 6 months at 30 °C - 40 °C after the last charge.



#### ATTENTION

The battery modules must not be stored overhead when switched off.



#### ATTENTION

When shipping or storing the UPS system, it is necessary to protect the UPS system from discharge.  
Battery modules.

## 6. USV FIRMWARE UPDATE

For the UPS-Control software see **UPS-Control-Software Manual**